



# REGULAMENTO BRASILEIRO DA AVIAÇÃO CIVIL

**RBAC nº 36**

**EMENDA nº 28**

---

<b>Título:</b>	<b>REQUISITOS DE RUÍDO PARA AERONAVE.</b>	
<b>Aprovação:</b>	Resolução ANAC N° 102, de 9 de junho de 2009, publicada no Diário Oficial da União N° 110, S/1, p.34, de 12/06/2009.	<b>Origem:</b> SAR

---

## SUMÁRIO

36.00 Requisitos da adoção

APÊNDICE A-I DO RBAC 36 – REPUBLICAÇÃO DO 14 CFR PART 36, EMENDA 36-28, ADOTADO PELO RBAC 36

## **36.00 Requisitos da adoção**

### **(a) Geral**

Para aprovação no Brasil, quanto aos requisitos para ruído de aeronave, será adotado integralmente, na língua inglesa, o regulamento **Title 14 Code of Federal Regulations Part 36**, Emenda 36-28, efetiva em 03 de fevereiro de 2006, da autoridade de aviação civil, **Federal Aviation Administration – FAA**, do **Department of Transportation** dos Estados Unidos da América, o qual é republicado no Apêndice A-I deste RBAC a partir do contido no sítio de publicação do regulamento adotado em pauta: <http://ecfr.gpoaccess.gov>.

### **(b) Divergência editorial**

Qualquer divergência editorial contida no Apêndice A-I decorrente da republicação ali contida e o texto oficial da **FAA** deverá prevalecer, mediante anuência da ANAC, o texto oficial da **FAA**.

### **(c) Republicação**

Sempre que houver emenda no regulamento **14 Code of Federal Regulations Part 36**, a ANAC republicará o texto do regulamento adotado na forma do Apêndice A-I, por meio de emendas a este RBAC.

### **(d) Emenda deste RBAC**

Especificamente para este RBAC a indicação de sua emenda também é através da adoção da emenda do regulamento adotado e republicado no Apêndice A-I deste RBAC, portanto seguindo a indicação da emenda do regulamento adotado e indicado no parágrafo (a) desta seção.

**APÊNDICE A-I DO RBAC 36  
REPUBLICAÇÃO DO 14 CFR PART 36, EMENDA 36-28, ADOTADO PELO RBAC 36**

**PART 36—NOISE STANDARDS: AIRCRAFT TYPE AND AIRWORTHINESS  
CERTIFICATION**

---

**Section Contents**

**Subpart A—General**

- § 36.1 Applicability and definitions.
- § 36.2 Requirements as of date of application.
- § 36.3 Compatibility with airworthiness requirements.
- § 36.5 Limitation of part.
- § 36.6 Incorporation by reference.
- § 36.7 Acoustical change: Transport category large airplanes and jet airplanes.
- § 36.9 Acoustical change: Propeller-driven small airplanes and propeller-driven commuter category airplanes.
- § 36.11 Acoustical change: Helicopters.

**Subpart B—Transport Category Large Airplanes and Jet Airplanes**

- § 36.101 Noise measurement and evaluation.
- § 36.103 Noise limits.
- § 36.105 Flight Manual Statement of Chapter 4 equivalency.

**Subpart C [Reserved]**

**Subpart D—Noise Limits for Supersonic Transport Category Airplanes**

- § 36.301 Noise limits: Concorde.

**Subpart E [Reserved]**

**Subpart F—Propeller Driven Small Airplanes and Propeller-Driven, Commuter Category Airplanes**

**§ 36.501 Noise limits.**

**Subpart G [Reserved]**

**Subpart H—Helicopters**

**§ 36.801 Noise measurement.**

**§ 36.803 Noise evaluation and calculation.**

**§ 36.805 Noise limits.**

**Subparts I–N [Reserved]**

**Subpart O—Documentation, Operating Limitations and Information**

**§ 36.1501 Procedures, noise levels and other information.**

**§ 36.1581 Manuals, markings, and placards.**

**§ 36.1583 Noncomplying agricultural and fire fighting airplanes.**

**Appendix A to Part 36—Aircraft Noise Measurement and Evaluation Under §36.101**

**Appendix B to Part 36—Noise Levels for Transport Category and Jet Airplanes Under §36.103**

**Appendixes C–E to Part 36 [Reserved]**

**Appendix F to Part 36—Flyover Noise Requirements for Propeller-Driven Small Airplane and Propeller-Driven, Commuter Category Airplane Certification Tests Prior to December 22, 1988**

**Appendix G to Part 36—Takeoff Noise Requirements for Propeller-Driven Small Airplane and Propeller-Driven, Commuter Category Airplane Certification Tests on or After**

**December 22, 1988**

**Appendix H to Part 36—Noise Requirements For Helicopters Under Subpart H**

**Appendix I to Part 36 [Reserved]**

**Appendix J to Part 36—Alternative Noise Certification Procedure for Helicopters Under Subpart H Having a Maximum Certificated Takeoff Weight of Not More Than 7,000 Pounds**

---

**Authority:** 42 U.S.C. 4321 *et seq.* ; 49 U.S.C. 106(g), 40113, 44701–44702, 44704, 44715; sec. 305, Pub. L. 96–193, 94 Stat. 50, 57; E.O. 11514, 35 FR 4247, 3 CFR, 1966–1970 Comp., p. 902.

**Source:** Docket No. 9337, 34 FR 18364, Nov. 18, 1969, unless otherwise noted.

**Subpart A—General**

**§ 36.1 Applicability and definitions.**

- (a) This part prescribes noise standards for the issue of the following certificates:
- (1) Type certificates, and changes to those certificates, and standard airworthiness certificates, for subsonic transport category large airplanes, and for subsonic jet airplanes regardless of category.
  - (2) Type certificates and changes to those certificates, standard airworthiness certificates, and restricted category airworthiness certificates, for propeller-driven, small airplanes, and for propeller-driven, commuter category airplanes except those airplanes that are designed for “agricultural aircraft operations” (as defined in §137.3 of this chapter, as effective on January 1, 1966) or for dispersing fire fighting materials to which §36.1583 of this part does not apply.
  - (3) A type certificate and changes to that certificate, and standard airworthiness certificates, for Concorde airplanes.
  - (4) Type certificates, and changes to those certificates, for helicopters except those helicopters that are designated exclusively for “agricultural aircraft operations” (as defined in §137.3 of this chapter, as effective on January 1, 1966), for dispensing fire fighting materials, or for carrying external loads (as defined in §133.1(b) of this chapter, as effective on December 20, 1976).
- (b) Each person who applies under Part 21 of this chapter for a type of airworthiness certificate specified in this part must show compliance with the applicable requirements of this part, in addition to the applicable airworthiness requirements of this chapter.

- (c) Each person who applies under Part 21 of this chapter for approval of an acoustical change described in §21.93(b) of this chapter must show that the aircraft complies with the applicable provisions of §§36.7, 36.9, or 36.11 of this part in addition to the applicable airworthiness requirements of this chapter.
- (d) Each person who applies for the original issue of a standard airworthiness certificate for a transport category large airplane or for a jet airplane under §21.183 must, regardless of date of application, show compliance with the following provisions of this part (including appendix B):
- (1) The provisions of this part in effect on December 1, 1969, for subsonic airplanes that have not had any flight time before—
    - (i) December 1, 1973, for airplanes with maximum weights greater than 75,000 pounds, except for airplanes that are powered by Pratt & Whitney Turbo Wasp JT3D series engines;
    - (ii) December 31, 1974, for airplanes with maximum weights greater than 75,000 pounds and that are powered by Pratt & Whitney Turbo Wasp JT3D series engines; and
    - (iii) December 31, 1974, for airplanes with maximum weights of 75,000 pounds and less.
  - (2) The provisions of this part in effect on October 13, 1977, including the stage 2 noise limits, for Concorde airplanes that have not had flight time before January 1, 1980.
- (e) Each person who applies for the original issue of a standard airworthiness certificate under §21.183, or for the original issue of a restricted category airworthiness certificate under §21.185, for propeller-driven, commuter category airplanes for a propeller driven small airplane that has not had any flight time before January 1, 1980, must show compliance with the applicable provisions of this part.
- (f) For the purpose of showing compliance with this part for transport category large airplanes and jet airplanes regardless of category, the following terms have the following meanings:
- (1) A “Stage 1 noise level” means a flyover, lateral or approach noise level greater than the Stage 2 noise limits prescribed in section B36.5(b) of appendix B of this part.
  - (2) A “Stage 1 airplane” means an airplane that has not been shown under this part to comply with the flyover, lateral, and approach noise levels required for Stage 2 or Stage 3 airplanes.
  - (3) A “Stage 2 noise level” means a noise level at or below the Stage 2 noise limits prescribed in section B36.5(b) of appendix B of this part but higher than the Stage 3 noise limits prescribed in section B36.5(c) of appendix B of this part.
  - (4) A “Stage 2 airplane” means an airplane that has been shown under this part to comply with Stage 2 noise levels prescribed in section B36.5(b) of appendix B of this part (including use of the applicable tradeoff provisions specified in section B36.6) and that does not comply with the requirements for a Stage 3 airplane.
  - (5) A “Stage 3 noise level” means a noise level at or below the Stage 3 noise limits prescribed in

section B36.5(c) of appendix B of this part.

- (6) A “Stage 3 airplane” means an airplane that has been shown under this part to comply with Stage 3 noise levels prescribed in section B36.5(c) of appendix B of this part (including use of the applicable tradeoff provisions specified in section B36.6).
- (7) A “subsonic airplane” means an airplane for which the maximum operating limit speed,  $M_{mo}$ , does not exceed a Mach number of 1.
- (8) A “supersonic airplane” means an airplane for which the maximum operating limit speed,  $M_{mo}$ , exceeds a Mach number of 1.
- (9) A “Stage 4 noise level” means a noise level at or below the Stage 4 noise limit prescribed in section B36.5(d) of appendix B of this part.
- (10) A “Stage 4 airplane” means an airplane that has been shown under this part not to exceed the Stage 4 noise limit prescribed in section B36.5(d) of appendix B of this part.
- (11) A “Chapter 4 noise level” means a noise level at or below the maximum noise level prescribed in Chapter 4, Paragraph 4.4, Maximum Noise Levels, of the International Civil Aviation Organization (ICAO) Annex 16, Volume I, Amendment 7, effective March 21, 2002. [Incorporated by reference, see §36.6].
- (g) For the purpose of showing compliance with this part for transport category large airplanes and jet airplanes regardless of category, each airplane may not be identified as complying with more than one stage or configuration simultaneously.
- (h) For the purpose of showing compliance with this part, for helicopters in the primary, normal, transport, and restricted categories, the following terms have the specified meanings:
- (1) *Stage 1 noise level* means a takeoff, flyover, or approach noise level greater than the Stage 2 noise limits prescribed in section H36.305 of appendix H of this part, or a flyover noise level greater than the Stage 2 noise limits prescribed in section J36.305 of appendix J of this part.
- (2) *Stage 1 helicopter* means a helicopter that has not been shown under this part to comply with the takeoff, flyover, and approach noise levels required for Stage 2 helicopters as prescribed in section H36.305 of appendix H of this part, or a helicopter that has not been shown under this part to comply with the flyover noise level required for Stage 2 helicopters as prescribed in section J36.305 of appendix J of this part.
- (3) *Stage 2 noise level* means a takeoff, flyover, or approach noise level at or below the Stage 2 noise limits prescribed in section H36.305 of appendix H of this part, or a flyover noise level at or below the Stage 2 limit prescribed in section J36.305 of appendix J of this part.
- (4) *Stage 2 helicopter* means a helicopter that has been shown under this part to comply with Stage 2 noise limits (including applicable tradeoffs) prescribed in section H36.305 of appendix H of this part, or a helicopter that has been shown under this part to comply with the Stage 2

noise limit prescribed in section J36.305 of appendix J of this part.

- (5) *Maximum normal operating RPM* means the highest rotor speed corresponding to the airworthiness limit imposed by the manufacturer and approved by the FAA. Where a tolerance on the highest rotor speed is specified, the maximum normal operating rotor speed is the highest rotor speed for which that tolerance is given. If the rotor speed is automatically linked with flight condition, the maximum normal operating rotor speed corresponding with that flight condition must be used during the noise certification procedure. If rotor speed can be changed by pilot action, the highest normal operating rotor speed specified in the flight manual limitation section for power-on conditions must be used during the noise certification procedure.

[Doc. No. 13243, Amdt. 36–4, 40 FR 1034, Jan. 6, 1975]

**Editorial Note:** For Federal Register citations affecting §36.1, see the List of CFR Sections Affected, which appears in the Finding Aids section of the printed volume and on GPO Access.

### § 36.2 Requirements as of date of application.

- (a) Section 21.17 of this chapter notwithstanding, each person who applies for a type certificate for an aircraft covered by this part, must show that the aircraft meets the applicable requirements of this part that are effective on the date of application for that type certificate. When the time interval between the date of application for the type certificate and the issuance of the type certificate exceeds 5 years, the applicant must show that the aircraft meets the applicable requirements of this part that were effective on a date, to be selected by the applicant, not earlier than 5 years before the issue of the type certificate.
- (b) Section 21.101(a) of this chapter notwithstanding, each person who applies for an acoustical change to a type design specified in §21.93(b) of this chapter must show compliance with the applicable requirements of this part that are effective on the date of application for the change in type design. When the time interval between the date of application for the change in type design and the issuance of the amended or supplemental type certificate exceeds 5 years, the applicant must show that the aircraft meets the applicable requirements of this part that were effective on a date, to be selected by the applicant, not earlier than 5 years before the issue of the amended or supplemental type certificate.
- (c) If an applicant elects to comply with a standard in this part that was effective after the filing of the application for a type certificate or change to a type design, the election:
- (1) Must be approved by the FAA;
  - (2) Must include standards adopted between the date of application and the date of the election;
  - (3) May include other standards adopted after the standard elected by the applicant as determined by the FAA.

[Amdt. 36–54, 67 FR 45211, July 8, 2002; Amdt. 36–24, 67 FR 63195, Oct. 10, 2002]



### § 36.3 Compatibility with airworthiness requirements.

It must be shown that the aircraft meets the airworthiness regulations constituting the type certification basis of the aircraft under all conditions in which compliance with this part is shown, and that all procedures used in complying with this part, and all procedures and information for the flight crew developed under this part, are consistent with the airworthiness regulations constituting the type certification basis of the aircraft.

[Doc. No. 9337, 34 FR 18364, Nov. 18, 1969, as amended by Amdt. 36–14, 53 FR 3540, Feb. 5, 1988]

### § 36.5 Limitation of part.

Pursuant to 49 U.S.C. 1431(b)(4), the noise levels in this part have been determined to be as low as is economically reasonable, technologically practicable, and appropriate to the type of aircraft to which they apply. No determination is made, under this part, that these noise levels are or should be acceptable or unacceptable for operation at, into, or out of, any airport.

### § 36.6 Incorporation by reference.

- (a) *General.* This part prescribes certain standards and procedures which are not set forth in full text in the rule. Those standards and procedures are contained in published material which is reasonably available to the class of persons affected and has been approved for incorporation by reference by the Director of the Federal Register under 5 U.S.C. 552 (a) and 1 CFR Part 51.
- (b) *Incorporated matter.* (1) Each publication, or part of a publication, which is referenced but not set forth in full-text in this part and which is identified in paragraph (c) of this section is hereby incorporated by reference and made a part of Part 36 of this chapter with the approval of the Director of the Federal Register.
- (2) Incorporated matter which is subject to subsequent change is incorporated by reference according to the specific reference and to the identification statement. Adoption of any subsequent change in incorporated matter is made under Part 11 of this chapter and 1 CFR Part 51.
- (c) *Identification statement.* The complete title or description which identifies each published matter incorporated by reference in this part is as follows:
- (1) *International Electrotechnical Commission (IEC) Publications.* (i) IEC Publication No. 179, entitled “Precision Sound Level Meters,” dated 1973.
- (ii) IEC Publication No. 225, entitled “Octave, Half-Octave, Third Octave Band Filters Intended for the Analysis of Sounds and Vibrations,” dated 1966.
- (iii) IEC Publication No. 651, entitled “Sound Level Meters,” first edition, dated 1979.
- (iv) IEC Publication No. 561, entitled “Electro-acoustical Measuring Equipment for Aircraft Noise

Certification,” first edition, dated 1976.

- (v) IEC Publication No. 804, entitled “Integrating-averaging Sound Level Meters,” first edition, dated 1985.
  - (vi) IEC Publication 61094–3, entitled “Measurement Microphones—Part 3: Primary Method for Free-Field Calibration of Laboratory Standard Microphones by the Reciprocity Technique”, edition 1.0, dated 1995.
  - (vii) IEC Publication 61094–4, entitled “Measurement Microphones—Part 4: Specifications for Working Standard Microphones”, edition 1.0, dated 1995.
  - (viii) IEC Publication 61260, entitled “Electroacoustics-Octave-Band and Fractional-Octave-Band filters”, edition 1.0, dated 1995.
  - (ix) IEC Publication 61265, entitled “Instruments for Measurement of Aircraft Noise-Performance Requirements for Systems to Measure One-Third-Octave-Band Sound pressure Levels in Noise Certification of Transport-Category Aeroplanes,” edition 1.0, dated 1995.
  - (x) IEC Publication 60942, entitled “Electroacoustics—Sound Calibrators,” edition 2.0, dated 1997.
- (2) *Society of Automotive Engineers (SAE) Publications.* (i) SAE ARP 866A, entitled “Standard Values at Atmospheric Absorption as a Function of Temperature and Humidity for Use in Evaluating Aircraft Flyover Noise,” dated March 15, 1975.
- (3) International Standards and Recommended Practices entitled “Environmental Protection, Annex 16 to the Convention on International Civil Aviation, Volume I, Aircraft Noise”, Third Edition, July 1993, Amendment 7, effective March 21, 2002.
- (d) *Availability for purchase.* Published material incorporated by reference in this part may be purchased at the price established by the publisher or distributor at the following mailing addresses:
- (1) *IEC publications.*
    - (i) International Electrotechnical Commission, 3, rue de Varembe, Case postale 131, 1211 Geneva 20, Switzerland.
    - (ii) American National Standard Institute, 11 West 42nd Street, New York City, New York 10036.
  - (2) *SAE publications.* Society of Automotive Engineers, Inc., 400 Commonwealth Drive, Warrentown, Pennsylvania 15096.
  - (3) *ICAO publications.* International Civil Aviation Organization (ICAO), Document Sales Unit, 999 University Street, Montreal, Quebec H3C 5H7, Canada.
- (e) *Availability for inspection.* A copy of each publication incorporated by reference in this part is available for public inspection at the following locations:

- (1) U.S. Department of Transportation, Docket Operations, West Building Ground Floor, Room W12-140, 1200 New Jersey Avenue, SE., Washington, DC 20590.
- (2) The National Archives and Records Administration (NARA). For information on the availability of this material at NARA, call 202-741-6030, or go to: [http://www.archives.gov/federal\\_register/code\\_of\\_federal\\_regulations/ibr\\_locations.html](http://www.archives.gov/federal_register/code_of_federal_regulations/ibr_locations.html).
- (3) The respective Region Headquarters of the Federal Aviation Administration as follows:
  - (i) New England Region Headquarters, 12 New England Executive Park, Burlington, Massachusetts 01803.
  - (ii) Eastern Region Headquarters, Federal Building, John F. Kennedy (JFK) International Airport, Jamaica, New York 11430.
  - (iii) Southern Region Headquarters, 1701 Columbia Avenue, College Park, Georgia, 30337.
  - (iv) Great Lakes Region Headquarters, O'Hare Lake Office Center, 2300 East Devon Avenue, Des Plaines, Illinois 60018.
  - (v) Central Region Headquarters, Federal Building, 601 East 12th Street, Kansas City Missouri 64106.
  - (vi) Southwest Region Headquarters, 2601 Meacham Boulevard, Fort Worth, Texas, 76137-4298.
  - (vii) Northwest Mountain Region Headquarters, 1601 Lind Avenue, Southwest, Renton, Washington 98055.
  - (viii) Western-Pacific Region Headquarters, 15000 Aviation Boulevard, Hawthorne, California 92007.
  - (ix) Alaskan Region Headquarters, 222 West 7th Avenue, #14, Anchorage, Alaska, 99513.
  - (x) European Office Headquarters, 15, Rue de la Loi (3rd Floor), B-1040 Brussels, Belgium.

[Amdt. 36-9, 43 FR 8739, Mar. 3, 1978, as amended by Amdt. 36-16, 53 FR 47400, Nov. 22, 1988; Amdt. 36-20, 57 FR 42854, Sept. 16, 1992; Amdt. 36-54, 67 FR 45212, July 8, 2002; Amdt. 36-24, 28 FR 1512, Jan. 10, 2003; 68 FR 2402, Jan. 16, 2003; Amdt. 36-26, 70 FR 38748, July 5, 2005; 72 FR 68475, Dec. 5, 2007]

### **§ 36.7 Acoustical change: Transport category large airplanes and jet airplanes.**

- (a) *Applicability.* This section applies to all transport category large airplanes and jet airplanes for which an acoustical change approval is applied for under §21.93(b) of this chapter.
- (b) *General requirements.* Except as otherwise specifically provided, for each airplane covered by this section, the acoustical change approval requirements are as follows:
  - (1) In showing compliance, noise levels must be measured and evaluated in accordance with the

applicable procedures and conditions prescribed in Appendix A of this part.

- (2) Compliance with the noise limits prescribed in section B36.5 of appendix B must be shown in accordance with the applicable provisions of sections B36.7 and B36.8 of appendix B of this part.
- (c) *Stage 1 airplanes.* For each Stage 1 airplane prior to the change in type design, in addition to the provisions of paragraph (b) of this section, the following apply:
- (1) If an airplane is a Stage 1 airplane prior to the change in type design, it may not, after the change in type design, exceed the noise levels created prior to the change in type design. The tradeoff provisions of section B36.6 of appendix B of this part may not be used to increase the Stage 1 noise levels, unless the aircraft qualifies as a Stage 2 airplane.
- (2) In addition, for an airplane for which application is made after September 17, 1971—
- (i) There may be no reduction in power or thrust below the highest airworthiness approved power or thrust, during the tests conducted before and after the change in type design; and
- (ii) During the flyover and lateral noise tests conducted before the change in type design, the quietest airworthiness approved configuration available for the highest approved takeoff weight must be used.
- (d) *Stage 2 airplanes.* If an airplane is a Stage 2 airplane prior to the change in type design, the following apply, in addition to the provisions of paragraph (b) of this section:
- (1) *Airplanes with high bypass ratio jet engines.* For an airplane that has jet engines with a bypass ratio of 2 or more before a change in type design—
- (i) The airplane, after the change in type design, may not exceed either (A) each Stage 3 noise limit by more than 3 EPNdB, or (B) each Stage 2 noise limit, whichever is lower:
- (ii) The tradeoff provisions of section B36.6 of appendix B of this part may be used in determining compliance under this paragraph with respect to the Stage 2 noise limit or to the Stage 3 plus 3 EPNdB noise limits, as applicable; and
- (iii) During the flyover and lateral noise test conducted before the change in type design, the quietest airworthiness approved configuration available for the highest approved takeoff weight must be used.
- (2) *Airplanes that do not have high bypass ratio jet engines.* For an airplane that does not have jet engines with a bypass ratio of 2 or more before a change in type design—
- (i) The airplane may not be a Stage 1 airplane after the change in type design; and
- (ii) During the flyover and lateral noise tests conducted before the change in type design, the quietest airworthiness approved configuration available for the highest approved takeoff weight must be used.

(e) *Stage 3 airplanes.* If an airplane is a Stage 3 airplane prior to the change in type design, the following apply, in addition to the provisions of paragraph (b) of this section:

(1) If compliance with Stage 3 noise levels is not required before the change in type design, the airplane must—

(i) Be a Stage 2 airplane after the change in type design and compliance must be shown under the provisions of paragraph (d)(1) or (d)(2) of this section, as appropriate; or

(ii) Remain a Stage 3 airplane after the change in type design. Compliance must be shown under the provisions of paragraph (e)(2) of this section.

(2) If compliance with Stage 3 noise levels is required before the change in type design, the airplane must be a Stage 3 airplane after the change in type design.

(3) Applications on or after [August 14, 1989.] The airplane must remain a Stage 3 airplane after the change in type design.

(4) If an airplane is a Stage 3 airplane prior to a change in type design, and becomes a Stage 4 after the change in type design, the airplane must remain a Stage 4 airplane.

(f) *Stage 4 airplanes.* If an airplane is a Stage 4 airplane prior to a change in type design, the airplane must remain a Stage 4 airplane after the change in type design.

[Amdt. 36–7, 42 FR 12371, Mar. 3, 1977; Amdt. 36–8, 43 FR 8730, Mar. 2, 1978; Amdt. 36–10, 43 FR 28420, June 29, 1978; Amdt. 36–12, 46 FR 33464, June 29, 1981; Amdt. 36–15, 53 FR 16366, May 6, 1988; 53 FR 18950, May 25, 1988; Amdt. 36–17, 54 FR 21042, May 15, 1989; Amdt. 36–54, 67 FR 45212, July 8, 2002; Amdt. 36–26, 70 FR 38749, July 5, 2005]

### **§ 36.9 Acoustical change: Propeller-driven small airplanes and propeller-driven commuter category airplanes.**

For propeller-driven small airplanes in the primary, normal, utility, acrobatic, transport, and restricted categories and for propeller-driven, commuter category airplanes for which an acoustical change approval is applied for under §21.93(b) of this chapter after January 1, 1975, the following apply:

(a) If the airplane was type certificated under this part prior to a change in type design, it may not subsequently exceed the noise limits specified in §36.501 of this part.

(b) If the airplane was not type certificated under this part prior to a change in type design, it may not exceed the higher of the two following values:

(1) The noise limit specified in §36.501 of this part, or

(2) The noise level created prior to the change in type design, measured and corrected as prescribed in §36.501 of this part.

[Amdt. 36–16, 53 FR 47400, Nov. 22, 1988; 53 FR 50157, Dec. 13, 1988; Amdt. 36–19, 57 FR

41369, Sept. 9, 1992]

### § 36.11 Acoustical change: Helicopters.

This section applies to all helicopters in the primary, normal, transport, and restricted categories for which an acoustical change approval is applied for under §21.93(b) of this chapter on or after March 6, 1986. Compliance with the requirements of this section must be demonstrated under appendix H of this part, or, for helicopters having a maximum certificated takeoff weight of not more than 7,000 pounds, compliance with this section may be demonstrated under appendix J of this part.

(a) *General requirements.* Except as otherwise provided, for helicopters covered by this section, the acoustical change approval requirements are as follows:

(1) In showing compliance with the requirements of appendix H of this part, noise levels must be measured, evaluated, and calculated in accordance with the applicable procedures and conditions prescribed in parts B and C of appendix H of this part. For helicopters having a maximum certificated takeoff weight of not more than 7,000 pounds that alternatively demonstrate compliance under appendix J of this part, the flyover noise level prescribed in appendix J of this part must be measured, evaluated, and calculated in accordance with the applicable procedures and conditions prescribed in parts B and C of appendix J of this part.

(2) Compliance with the noise limits prescribed in section H36.305 of appendix H of this part must be shown in accordance with the applicable provisions of part D of appendix H of this part. For those helicopters that demonstrate compliance with the requirements of appendix J of this part, compliance with the noise levels prescribed in section J36.305 of appendix J of this part must be shown in accordance with the applicable provisions of part D of appendix J of this part.

(b) *Stage 1 helicopters.* Except as provided in §36.805(c), for each Stage 1 helicopter prior to a change in type design, the helicopter noise levels may not, after a change in type design, exceed the noise levels specified in section H36.305(a)(1) of appendix H of this part where the demonstration of compliance is under appendix H of this part. The tradeoff provisions under section H36.305(b) of appendix H of this part may not be used to increase any Stage 1 noise level beyond these limits. If an applicant chooses to demonstrate compliance under appendix J of this part, for each Stage 1 helicopter prior to a change in type design, the helicopter noise levels may not, after a change in type design, exceed the Stage 2 noise levels specified in section J36.305(a) of appendix J of this part.

(c) *Stage 2 helicopters.* For each helicopter that is Stage 2 prior to a change in type design, the helicopter must be a Stage 2 helicopter after a change in type design.

[Doc. No. 26910, 57 FR 42854, Sept. 16, 1992, as amended by Amdt. 36–25, 69 FR 31234, June 2, 2004]

## Subpart B—Transport Category Large Airplanes and Jet Airplanes

### § 36.101 Noise measurement and evaluation.

For transport category large airplanes and jet airplanes, the noise generated by the airplane must be measured and evaluated under appendix A of this part or under an approved equivalent procedure.

[Amdt. 36–54, 67 FR 45212, July 8, 2002]

### **§ 36.103 Noise limits.**

- (a) For subsonic transport category large airplanes and subsonic jet airplanes compliance with this section must be shown with noise levels measured and evaluated as prescribed in appendix A of this part, and demonstrated at the measuring points, and in accordance with the test procedures under section B36.8 (or an approved equivalent procedure), stated under appendix B of this part.
- (b) Type certification applications between November 5, 1975 and December 31, 2005. If application is made on or after November 5, 1975, and before January 1, 2006, it must be shown that the noise levels of the airplane are no greater than the Stage 3 noise limit prescribed in section B36.5(c) of appendix B of this part.
- (c) Type certification applications on or after January 1, 2006. If application is made on or after January 1, 2006, it must be shown that the noise levels of the airplane are no greater than the Stage 4 noise limit prescribed in section B36.5(d) of appendix B of this part. Prior to January 1, 2006, an applicant may seek voluntary certification to Stage 4. If Stage 4 certification is chosen, the requirements of §36.7(f) of this part will apply.

[Amdt. 36–54, 67 FR 45212, July 8, 2002, as amended by Amdt. 36–26, 70 FR 38749, July 5, 2005]

### **§ 36.105 Flight Manual Statement of Chapter 4 equivalency.**

For each airplane that meets the requirements for Stage 4 certification, the Airplane Flight Manual or operations manual must include the following statement: “The following noise levels comply with part 36, Appendix B, Stage 4 maximum noise level requirements and were obtained by analysis of approved data from noise tests conducted under the provisions of part 36, Amendment 36 (insert part 36 amendment to which the airplane was certificated). The noise measurement and evaluation procedures used to obtain these noise levels are considered by the FAA to be equivalent to the Chapter 4 noise level required by the International Civil Aviation Organization (ICAO) in Annex 16, Volume I, Appendix 2, Amendment 7, effective March 21, 2002.” [Incorporated by reference, see §36.6].

[Amdt. 36–26, 70 FR 38749, July 5, 2005; 70 FR 41610, July 20, 2005]

### **Subpart C [Reserved]**

### **Subpart D—Noise Limits for Supersonic Transport Category Airplanes**

#### **§ 36.301 Noise limits: Concorde.**

- (a) *General.* For the Concorde airplane, compliance with this subpart must be shown with noise

levels measured and evaluated as prescribed in Subpart B of this part, and demonstrated at the measuring points prescribed in appendix B of this part.

- (b) *Noise limits.* It must be shown, in accordance with the provisions of this part in effect on October 13, 1977, that the noise levels of the airplane are reduced to the lowest levels that are economically reasonable, technologically practicable, and appropriate for the Concorde type design.

[Amdt. 36–10, 43 FR 28420, June 29, 1978, as amended by Amdt. 36–54, 67 FR 45212, July 8, 2002]

## **Subpart E [Reserved]**

## **Subpart F—Propeller Driven Small Airplanes and Propeller-Driven, Commuter Category Airplanes**

### **§ 36.501 Noise limits.**

- (a) Compliance with this subpart must be shown for—

- (1) Propeller driven small airplanes for which application for the issuance of a new, amended, or supplemental type certificate in the normal, utility, acrobatic, transport, or restricted category is made on or after October 10, 1973; and propeller-driven, commuter category airplanes for which application for the issuance of a type certificate in the commuter category is made on or after January 15, 1987.
- (2) Propeller driven small airplanes and propeller-driven, commuter category airplanes for which application is made for the original issuance of a standard airworthiness certificate or restricted category airworthiness certificate, and that have not had any flight time before January 1, 1980 (regardless of date of application).
- (3) Airplanes in the primary category:
  - (i) Except as provided in paragraph (a)(3)(ii) of this section, for an airplane for which application for a type certificate in the primary category is made, and that was not previously certificated under appendix F of this part, compliance with appendix G of this part must be shown.
  - (ii) For an airplane in the normal, utility or acrobatic category that (A) has a type certificate issued under this chapter, (B) has a standard airworthiness certificate issued under this chapter, (C) has not undergone an acoustical change from its type design, (D) has not previously been certificated under appendix F or G of this part, and (E) for which application for conversion to the primary category is made, no further showing of compliance with this part is required.
- (b) For aircraft covered by this subpart for which certification tests are completed before December 22, 1988, compliance must be shown with noise levels as measured and prescribed in Parts B and C of appendix F, or under approved equivalent procedures. It must be shown that the noise level of the airplane is no greater than the applicable limit set in Part D of appendix



F.

- (c) For aircraft covered by this subpart for which certification tests are not completed before December 22, 1988, compliance must be shown with noise levels as measured and prescribed in Parts B and C of appendix G, or under approved equivalent procedures. It must be shown that the noise level of the airplane is no greater than the applicable limits set in Part D of appendix G.

[Doc. No. 13243, 40 FR 1034, Jan. 6, 1975, as amended by Amdt. 36–13, 52 FR 1836, Jan. 15, 1987; Amdt. 36–16, 53 FR 47400, Nov. 22, 1988; Amdt. 36–19, 57 FR 41369, Sept. 9, 1992]

### **Subpart G [Reserved]**

### **Subpart H—Helicopters**

**Source:** Amdt. 36–14, 53 FR 3540, Feb. 5, 1988; 53 FR 7728, Mar. 10, 1988, unless otherwise noted.

#### **§ 36.801 Noise measurement.**

For primary, normal, transport, or restricted category helicopters for which certification is sought under appendix H of this part, the noise generated by the helicopter must be measured at the noise measuring points and under the test conditions prescribed in part B of appendix H of this part, or under an FAA-approved equivalent procedure. For those primary, normal, transport, and restricted category helicopters having a maximum certificated takeoff weight of not more than 7,000 pounds for which compliance with appendix J of this part is demonstrated, the noise generated by the helicopter must be measured at the noise measuring point and under the test conditions prescribed in part B of appendix J of this part, or an FAA-approved equivalent procedure.

[Doc. No. 26910, 57 FR 42854, Sept. 16, 1992, as amended by Amdt. 36–25, 69 FR 31234, June 2, 2004]

#### **§ 36.803 Noise evaluation and calculation.**

The noise measurement data required under §36.801 and obtained under appendix H of this part must be corrected to the reference conditions contained in part A of appendix H of this part, and evaluated under the procedures of part C of appendix H of this part, or an FAA-approved equivalent procedure. The noise measurement data required under §36.801 and obtained under appendix J of this part must be corrected to the reference conditions contained in part A of appendix J of this part, and evaluated under the procedures of part C of appendix J of this part, or an FAA-approved equivalent procedure.

[Doc. No. 26910, 57 FR 42854, Sept. 16, 1992]

#### **§ 36.805 Noise limits.**

- (a) Compliance with the noise levels prescribed under part D of appendix H of this part, or under

part D of appendix J of this part, must be shown for helicopters for which application for issuance of a type certificate in the primary, normal, transport, or restricted category is made on or after March 6, 1986.

- (b) For helicopters covered by this section, except as provided in paragraph (c) or (d)(2) of this section, it must be shown either:
- (1) For those helicopters demonstrating compliance under appendix H of this part, the noise levels of the helicopter are no greater than the applicable limits prescribed under section H36.305 of appendix H of this part, or
  - (2) For helicopters demonstrating compliance under appendix J of this part, the noise level of the helicopter is no greater than the limit prescribed under section J36.305 of appendix J of this part.
- (c) For helicopters for which application for issuance of an original type certificate in the primary, normal, transport, or restricted category is made on or after March 6, 1986, and which the FAA finds to be the first civil version of a helicopter that was designed and constructed for, and accepted for operational use by, an Armed Force of the United States or the U.S. Coast Guard on or before March 6, 1986, it must be shown that the noise levels of the helicopter are no greater than the noise limits for a change in type design as specified in section H36.305(a)(1)(ii) of appendix H of this part for compliance demonstrated under appendix H of this part, or as specified in section J36.305 of appendix J of this part for compliance demonstrated under appendix J of this part. Subsequent civil versions of any such helicopter must meet the Stage 2 requirements.
- (d) Helicopters in the primary category:
- (1) Except as provided in paragraph (d)(2) of this section, for a helicopter for which application for a type certificate in the primary category is made, and that was not previously certificated under appendix H of this part, compliance with appendix H of this part must be shown.
  - (2) For a helicopter that:
    - (i) Has a normal or transport type certificate issued under this chapter,
    - (ii) Has a standard airworthiness certificate issued under this chapter,
    - (iii) Has not undergone an acoustical change from its type design,
    - (iv) Has not previously been certificated under appendix H of this part, and
    - (v) For which application for conversion to the primary category is made, no further showing of compliance with this part is required.

[Doc. No. 26910, 57 FR 42855, Sept. 16, 1992]

### **Subparts I–N [Reserved]**

**Subpart O—Documentation, Operating Limitations and Information****§ 36.1501 Procedures, noise levels and other information.**

- (a) All procedures, weights, configurations, and other information or data employed for obtaining the certified noise levels prescribed by this part, including equivalent procedures used for flight, testing, and analysis, must be developed and approved. Noise levels achieved during type certification must be included in the approved airplane (rotorcraft) flight manual.
- (b) Where supplemental test data are approved for modification or extension of an existing flight data base, such as acoustic data from engine static tests used in the certification of acoustical changes, the test procedures, physical configuration, and other information and procedures that are employed for obtaining the supplemental data must be developed and approved.

[Amdt. 36–15, 53 FR 16366, May 6, 1988]

**§ 36.1581 Manuals, markings, and placards.**

- (a) If an Airplane Flight Manual or Rotorcraft Flight Manual is approved, the approved portion of the Airplane Flight Manual or Rotorcraft Flight Manual must contain the following information, in addition to that specified under §36.1583 of this part. If an Airplane Flight Manual or Rotorcraft Flight Manual is not approved, the procedures and information must be furnished in any combination of approved manual material, markings, and placards.
  - (1) For transport category large airplanes and jet airplanes, the noise level information must be one value for each flyover, lateral, and approach as defined and required by appendix B of this part, along with the maximum takeoff weight, maximum landing weight, and configuration.
  - (2) For propeller driven small airplanes, the noise level information must be one value for takeoff as defined and required by appendix G of this part, along with the maximum takeoff weight and configuration.
  - (3) For rotorcraft, the noise level information must be one value for each takeoff, flyover, and approach as defined and required by appendix H of this part, or one value for flyover as defined and required by appendix J of this part, at the maximum takeoff weight and configuration.
- (b) If supplemental operational noise level information is included in the approved portion of the Airplane Flight Manual, it must be segregated, identified as information in addition to the certificated noise levels, and clearly distinguished from the information required under §36.1581(a).
- (c) The following statement must be furnished near the listed noise levels:

No determination has been made by the Federal Aviation Administration that the noise levels of this aircraft are or should be acceptable or unacceptable for operation at, into, or out of, any

airport.

- (d) For transport category large airplanes and jet airplanes, for which the weight used in meeting the takeoff or landing noise requirements of this part is less than the maximum weight established under the applicable airworthiness requirements, those lesser weights must be furnished, as operating limitations in the operating limitations section of the Airplane Flight Manual. Further, the maximum takeoff weight must not exceed the takeoff weight that is most critical from a takeoff noise standpoint.
- (e) For propeller driven small airplanes and for propeller-driven, commuter category airplanes for which the weight used in meeting the flyover noise requirements of this part is less than the maximum weight by an amount exceeding the amount of fuel needed to conduct the test, that lesser weight must be furnished, as an operating limitation, in the operating limitations section of an approved Airplane Flight Manual, in approved manual material, or on an approved placard.
- (f) For primary, normal, transport, and restricted category helicopters, if the weight used in meeting the takeoff, flyover, or approach noise requirements of appendix H of this part, or the weight used in meeting the flyover noise requirement of appendix J of this part, is less than the certificated maximum takeoff weight established under either §27.25(a) or §29.25(a) of this chapter, that lesser weight must be furnished as an operating limitation in the operating limitations section of the Rotorcraft Flight Manual, in FAA-approved manual material, or on an FAA-approved placard.
- (g) Except as provided in paragraphs (d), (e), and (f) of this section, no operating limitations are furnished under this part.

[Doc. 13243, 40 FR 1035, Jan. 6, 1975]

**Editorial Note:** For Federal Register citations affecting §36.1581, see the List of CFR Sections Affected, which appears in the Finding Aids section of the printed volume and on GPO Access.

### § 36.1583 Noncomplying agricultural and fire fighting airplanes.

- (a) This section applies to propeller-driven, small airplanes that—
  - (1) Are designed for “agricultural aircraft operations” (as defined in §137.3 of this chapter, effective on January 1, 1966) or for dispensing fire fighting materials; and
  - (2) Have not been shown to comply with the noise levels prescribed under appendix F of this part—
    - (i) For which application is made for the original issue of a standard airworthiness certificate and that do not have any flight time before January 1, 1980; or
    - (ii) For which application is made for an acoustical change approval, for airplanes which have a standard airworthiness certificate after the change in the type design, and that do not have any flight time in the changed configuration before January 1, 1980.

- (b) For airplanes covered by this section an operating limitation reading as follows must be furnished in the manner prescribed in §36.1581:

Noise abatement: This airplane has not been shown to comply with the noise limits in FAR Part 36 and must be operated in accordance with the noise operating limitation prescribed under FAR §91.815.

[Amdt. 36–11, 45 FR 67066, Oct. 9, 1980. Redesignated by Amdt. 36–14, 53 FR 3540, Feb. 5, 1988; Amdt. 36–18, 54 FR 34330, Aug. 18, 1989]

## **Appendix A to Part 36—Aircraft Noise Measurement and Evaluation Under §36.101**

Sec.

A36.1 *Introduction.*

A36.2 *Noise Certification Test and Measurement Conditions.*

A36.3 *Measurement of Airplane Noise Received on the Ground.*

A36.4 *Calculations of Effective Perceived Noise Level From Measured Data.*

A36.5 *Reporting of Data to the FAA.*

A36.6 *Nomenclature: Symbols and Units.*

A36.7 *Sound Attenuation in Air.*

A36.8 [Reserved]

A36.9 *Adjustment of Airplane Flight Test Results.*

### *Section A36.1 Introduction*

A36.1.1 This appendix prescribes the conditions under which airplane noise certification tests must be conducted and states the measurement procedures that must be used to measure airplane noise. The procedures that must be used to determine the noise evaluation quantity designated as effective perceived noise level, EPNL, under §§36.101 and 36.803 are also stated.

A36.1.2 The instructions and procedures given are intended to ensure uniformity during compliance tests and to permit comparison between tests of various types of airplanes conducted in various geographical locations.

A36.1.3 A complete list of symbols and units, the mathematical formulation of perceived noisiness, a procedure for determining atmospheric attenuation of sound, and detailed procedures for correcting noise levels from non-reference to reference conditions are included in this appendix.

A36.1.4 For Stage 4 airplanes, an acceptable alternate for noise measurement and evaluation is Appendix 2 to the International Civil Aviation Organization (ICAO) Annex 16, Environmental Protection, Volume I, Aircraft Noise, Third Edition, July 1993, Amendment 7, effective March 21, 2002. [Incorporated by reference, see §36.6].

### *Section A36.2 Noise Certification Test and Measurement Conditions*

#### *A36.2.1 General.*

A36.2.1.1 This section prescribes the conditions under which noise certification must be conducted and the measurement procedures that must be used.

Note: Many noise certifications involve only minor changes to the airplane type design. The resulting changes in noise can often be established reliably without resorting to a complete test as outlined in this appendix. For this reason, the FAA permits the use of approved equivalent procedures. There are also equivalent procedures that may be used in full certification tests, in the interest of reducing costs and providing reliable results. Guidance material on the use of equivalent procedures in the noise certification of subsonic jet and propeller-driven large airplanes is provided in the current advisory circular for this part.

#### *A36.2.2 Test environment.*

A36.2.2.1 Locations for measuring noise from an airplane in flight must be surrounded by relatively flat terrain having no excessive sound absorption characteristics such as might be caused by thick, matted, or tall grass, shrubs, or wooded areas. No obstructions that significantly influence the sound field from the airplane must exist within a conical space above the point on the ground vertically below the microphone, the cone being defined by an axis normal to the ground and by a half-angle 80° from this axis.

Note: Those people carrying out the measurements could themselves constitute such obstruction.

A36.2.2.2 The tests must be carried out under the following atmospheric conditions.

(a) No precipitation;

(b) Ambient air temperature not above 95 °F (35 °C) and not below 14 °F (–10 °C), and relative humidity not above 95% and not below 20% over the whole noise path between a point 33 ft (10 m) above the ground and the airplane;

Note: Care should be taken to ensure that the noise measuring, airplane flight path tracking, and meteorological instrumentation are also operated within their specific environmental limitations.

(c) Relative humidity and ambient temperature over the whole noise path between a point 33 ft (10 m) above the ground and the airplane such that the sound attenuation in the one-third octave band centered on 8 kHz will not be more than 12 dB/100 m unless:

(1) The dew point and dry bulb temperatures are measured with a device which is accurate to ±0.9 °F (±0.5 °C) and used to obtain relative humidity; in addition layered sections of the

atmosphere are used as described in section A36.2.2.3 to compute equivalent weighted sound attenuations in each one-third octave band; or

- (2) The peak noise values at the time of PNLTM, after adjustment to reference conditions, occur at frequencies less than or equal to 400 Hz.;
- (d) If the atmospheric absorption coefficients vary over the PNLTM sound propagation path by more than  $\pm 1.6$  dB/1000 ft ( $\pm 0.5$  dB/100m) in the 3150Hz one-third octave band from the value of the absorption coefficient derived from the meteorological measurement obtained at 33 ft (10 m) above the surface, “layered” sections of the atmosphere must be used as described in section A36.2.2.3 to compute equivalent weighted sound attenuations in each one-third octave band; the FAA will determine whether a sufficient number of layered sections have been used. For each measurement, where multiple layering is not required, equivalent sound attenuations in each one-third octave band must be determined by averaging the atmospheric absorption coefficients for each such band at 33 ft (10 m) above ground level, and at the flight level of the airplane at the time of PNLTM, for each measurement;
- (e) Average wind velocity 33 ft (10 m) above ground may not exceed 12 knots and the crosswind velocity for the airplane may not exceed 7 knots. The average wind velocity must be determined using a 30-second averaging period spanning the 10 dB-down time interval. Maximum wind velocity 33 ft (10 m) above ground is not to exceed 15 knots and the crosswind velocity is not to exceed 10 knots during the 10 dB-down time interval;
- (f) No anomalous meteorological or wind conditions that would significantly affect the measured noise levels when the noise is recorded at the measuring points specified by the FAA; and
- (g) Meteorological measurements must be obtained within 30 minutes of each noise test measurement; meteorological data must be interpolated to actual times of each noise measurement.

A36.2.2.3 When a multiple layering calculation is required by section A36.2.2.2(c) or A36.2.2.2(d) the atmosphere between the airplane and 33 ft (10 m) above the ground must be divided into layers of equal depth. The depth of the layers must be set to not more than the depth of the narrowest layer across which the variation in the atmospheric absorption coefficient of the 3150 Hz one-third octave band is not greater than  $\pm 1.6$  dB/1000 ft ( $\pm 0.5$  dB/100m), with a minimum layer depth of 100 ft (30 m). This requirement must be met for the propagation path at PNLTM. The mean of the values of the atmospheric absorption coefficients at the top and bottom of each layer may be used to characterize the absorption properties of each layer.

A36.2.2.4 The airport control tower or another facility must be approved by the FAA for use as the central location at which measurements of atmospheric parameters are representative of those conditions existing over the geographical area in which noise measurements are made.

### A36.2.3 *Flight path measurement.*

A36.2.3.1 The airplane height and lateral position relative to the flight track must be determined by

a method independent of normal flight instrumentation such as radar tracking, theodolite triangulation, or photographic scaling techniques, to be approved by the FAA.

A36.2.3.2 The airplane position along the flight path must be related to the noise recorded at the noise measurement locations by means of synchronizing signals over a distance sufficient to assure adequate data during the period that the noise is within 10 dB of the maximum value of PNLT.

A36.2.3.3 Position and performance data required to make the adjustments referred to in section A36.9 of this appendix must be automatically recorded at an approved sampling rate. Measuring equipment must be approved by the FAA.

### *Section A36.3 Measurement of Airplane Noise Received on the Ground*

#### *A36.3.1 Definitions.*

For the purposes of section A36.3 the following definitions apply:

A36.3.1.1 *Measurement system* means the combination of instruments used for the measurement of sound pressure levels, including a sound calibrator, windscreen, microphone system, signal recording and conditioning devices, and one-third octave band analysis system.

Note: Practical installations may include a number of microphone systems, the outputs from which are recorded simultaneously by a multi-channel recording/analysis device via signal conditioners, as appropriate. For the purpose of this section, each complete measurement channel is considered to be a measurement system to which the requirements apply accordingly.

A36.3.1.2 *Microphone system* means the components of the measurement system which produce an electrical output signal in response to a sound pressure input signal, and which generally include a microphone, a preamplifier, extension cables, and other devices as necessary.

A36.3.1.3 *Sound incidence angle* means in degrees, an angle between the principal axis of the microphone, as defined in IEC 61094-3 and IEC 61094-4, as amended and a line from the sound source to the center of the diaphragm of the microphone.

Note: When the sound incidence angle is 0°, the sound is said to be received at the microphone at “normal (perpendicular) incidence;” when the sound incidence angle is 90°, the sound is said to be received at “grazing incidence.”

A36.3.1.4 *Reference direction* means, in degrees, the direction of sound incidence specified by the manufacturer of the microphone, relative to a sound incidence angle of 0°, for which the free-field sensitivity level of the microphone system is within specified tolerance limits.

A36.3.1.5 *Free-field sensitivity of a microphone system* means, in volts per Pascal, for a sinusoidal plane progressive sound wave of specified frequency, at a specified sound incidence angle, the quotient of the root mean square voltage at the output of a microphone system and the root mean square sound pressure that would exist at the position of the microphone in its



absence.

A36.3.1.6 *Free-field sensitivity level of a microphone system* means, in decibels, twenty times the logarithm to the base ten of the ratio of the free-field sensitivity of a microphone system and the reference sensitivity of one volt per Pascal.

Note: The free-field sensitivity level of a microphone system may be determined by subtracting the sound pressure level (in decibels re 20  $\mu$ Pa) of the sound incident on the microphone from the voltage level (in decibels re 1 V) at the output of the microphone system, and adding 93.98 dB to the result.

A36.3.1.7 *Time-average band sound pressure level* means in decibels, ten times the logarithm to the base ten, of the ratio of the time mean square of the instantaneous sound pressure during a stated time interval and in a specified one-third octave band, to the square of the reference sound pressure of 20  $\mu$ Pa.

A36.3.1.8 *Level range* means, in decibels, an operating range determined by the setting of the controls that are provided in a measurement system for the recording and one-third octave band analysis of a sound pressure signal. The upper boundary associated with any particular level range must be rounded to the nearest decibel.

A36.3.1.9 *Calibration sound pressure level* means, in decibels, the sound pressure level produced, under reference environmental conditions, in the cavity of the coupler of the sound calibrator that is used to determine the overall acoustical sensitivity of a measurement system.

A36.3.1.10 *Reference level range* means, in decibels, the level range for determining the acoustical sensitivity of the measurement system and containing the calibration sound pressure level.

A36.3.1.11 *Calibration check frequency* means, in hertz, the nominal frequency of the sinusoidal sound pressure signal produced by the sound calibrator.

A36.3.1.12 *Level difference* means, in decibels, for any nominal one-third octave midband frequency, the output signal level measured on any level range minus the level of the corresponding electrical input signal.

A36.3.1.13 *Reference level difference* means, in decibels, for a stated frequency, the level difference measured on a level range for an electrical input signal corresponding to the calibration sound pressure level, adjusted as appropriate, for the level range.

A36.3.1.14 *Level non-linearity* means, in decibels, the level difference measured on any level range, at a stated one-third octave nominal midband frequency, minus the corresponding reference level difference, all input and output signals being relative to the same reference quantity.

A36.3.1.15 *Linear operating range* means, in decibels, for a stated level range and frequency, the range of levels of steady sinusoidal electrical signals applied to the input of the entire measurement system, exclusive of the microphone but including the microphone preamplifier and any other signal-conditioning elements that are considered to be part of

the microphone system, extending from a lower to an upper boundary, over which the level non-linearity is within specified tolerance limits.

Note: Microphone extension cables as configured in the field need not be included for the linear operating range determination.

A36.3.1.16 *Windscreen insertion loss* means, in decibels, at a stated nominal one-third octave midband frequency, and for a stated sound incidence angle on the inserted microphone, the indicated sound pressure level without the windscreen installed around the microphone minus the sound pressure level with the windscreen installed.

A36.3.2 *Reference environmental conditions.*

A36.3.2.1 The reference environmental conditions for specifying the performance of a measurement system are:

- (a) Air temperature 73.4 °F (23 °C);
- (b) Static air pressure 101.325 kPa; and
- (c) Relative humidity 50%.

A36.3.3. *General.*

Note: Measurements of aircraft noise that are made using instruments that conform to the specifications of this section will yield one-third octave band sound pressure levels as a function of time. These one-third octave band levels are to be used for the calculation of effective perceived noise level as described in section A36.4.

A36.3.3.1 The measurement system must consist of equipment approved by the FAA and equivalent to the following:

- (a) A windscreen (See A36.3.4.);
- (b) A microphone system (See A36.3.5):
- (c) A recording and reproducing system to store the measured aircraft noise signals for subsequent analysis (see A36.3.6);
- (d) A one-third octave band analysis system (see A36.3.7); and
- (e) Calibration systems to maintain the acoustical sensitivity of the above systems within specified tolerance limits (see A36.3.8).

A36.3.3.2. For any component of the measurement system that converts an analog signal to digital form, such conversion must be performed so that the levels of any possible aliases or artifacts of the digitization process will be less than the upper boundary of the linear operating range by at least 50 dB at any frequency less than 12.5 kHz. The sampling rate must be at least 28 kHz. An anti-aliasing filter must be included before the digitization

process.

#### A36.3.4 *Windscreen.*

A36.3.4.1 In the absence of wind and for sinusoidal sounds at grazing incidence, the insertion loss caused by the windscreen of a stated type installed around the microphone must not exceed  $\pm 1.5$  dB at nominal one-third octave midband frequencies from 50 Hz to 10 kHz inclusive.

#### A36.3.5 *Microphone system.*

A36.3.5.1 The microphone system must meet the specifications in sections A36.3.5.2 to A36.3.5.4. Various microphone systems may be approved by the FAA on the basis of demonstrated equivalent overall electroacoustical performance. Where two or more microphone systems of the same type are used, demonstration that at least one system conforms to the specifications in full is sufficient to demonstrate conformance.

Note: An applicant must still calibrate and check each system as required in section A36.3.9.

A36.3.5.2 The microphone must be mounted with the sensing element 4 ft (1.2 m) above the local ground surface and must be oriented for grazing incidence, i.e., with the sensing element substantially in the plane defined by the predicted reference flight path of the aircraft and the measuring station. The microphone mounting arrangement must minimize the interference of the supports with the sound to be measured. Figure A36–1 illustrates sound incidence angles on a microphone.

A36.3.5.3 The free-field sensitivity level of the microphone and preamplifier in the reference direction, at frequencies over at least the range of one-third-octave nominal midband frequencies from 50 Hz to 5 kHz inclusive, must be within  $\pm 1.0$  dB of that at the calibration check frequency, and within  $\pm 2.0$  dB for nominal midband frequencies of 6.3 kHz, 8 kHz and 10 kHz.

A36.3.5.4 For sinusoidal sound waves at each one-third octave nominal midband frequency over the range from 50 Hz to 10 kHz inclusive, the free-field sensitivity levels of the microphone system at sound incidence angles of 30°, 60°, 90°, 120° and 150°, must not differ from the free-field sensitivity level at a sound incidence angle of 0° (“normal incidence”) by more than the values shown in Table A36–1. The free-field sensitivity level differences at sound incidence angles between any two adjacent sound incidence angles in Table A36–1 must not exceed the tolerance limit for the greater angle.

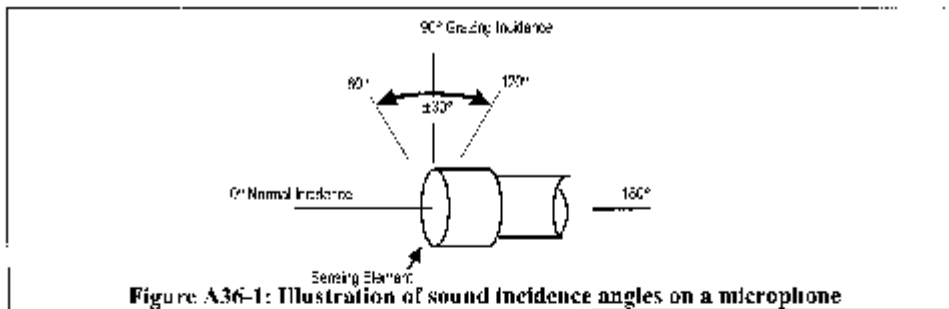

Nominal midband frequency kHz	Maximum difference between the free-field sensitivity level of a microphone system at normal incidence and the free-field sensitivity level at specified sound incidence angles dB				
	Sound Incidence angle degrees				
	30	60	90	120	150
0.05 to 1.6	0.5	0.5	1.0	1.0	1.0
2.0	0.5	0.5	1.0	1.0	1.0
2.5	0.5	0.5	1.0	1.5	1.5
3.15	0.5	1.0	1.5	2.0	2.0
4.0	0.5	1.0	2.0	2.5	2.5
5.0	0.5	1.5	2.5	3.0	3.0
6.3	1.0	2.0	3.0	4.0	4.0
8.0	1.5	2.5	4.0	5.5	5.5
10.0	2.0	3.5	5.5	6.5	7.5

**Table A36-1 Microphone Directional Response Requirements**

[View or download PDF](#)

**A36.3.6 Recording and reproducing systems.**

A36.3.6.1 A recording and reproducing system, such as a digital or analog magnetic tape recorder, a computer-based system or other permanent data storage device, must be used to store sound pressure signals for subsequent analysis. The sound produced by the aircraft must be recorded in such a way that a record of the complete acoustical signal is retained. The recording and reproducing systems must meet the specifications in sections A36.3.6.2 to A36.3.6.9 at the recording speeds and/or data sampling rates used for the noise certification tests. Conformance must be demonstrated for the frequency bandwidths and recording channels selected for the tests.

A36.3.6.2 The recording and reproducing systems must be calibrated as described in section A36.3.9.

- (a) For aircraft noise signals for which the high frequency spectral levels decrease rapidly with increasing frequency, appropriate pre-emphasis and complementary de-emphasis networks may be included in the measurement system. If pre-emphasis is included, over the range of nominal one-third octave midband frequencies from 800 Hz to 10 kHz inclusive, the electrical gain provided by the pre-emphasis network must not exceed 20 dB relative to the gain at 800 Hz.

A36.3.6.3 For steady sinusoidal electrical signals applied to the input of the entire measurement system including all parts of the microphone system except the microphone at a selected signal level within 5 dB of that corresponding to the calibration sound pressure level on the reference level range, the time-average signal level indicated by the readout device at any one-third octave nominal midband frequency from 50 Hz to 10 kHz inclusive must be within  $\pm 1.5$  dB of that at the calibration check frequency. The frequency response of a measurement system, which includes components that convert analog signals to digital form, must be within  $\pm 0.3$  dB of the response at 10 kHz over the frequency range from 10 kHz to 11.2 kHz.

Note: Microphone extension cables as configured in the field need not be included for the frequency response determination. This allowance does not eliminate the requirement of including microphone extension cables when performing the pink noise recording in section A36.3.9.5.

A36.3.6.4 For analog tape recordings, the amplitude fluctuations of a 1 kHz sinusoidal signal recorded within 5 dB of the level corresponding to the calibration sound pressure level must not vary by more than  $\pm 0.5$  dB throughout any reel of the type of magnetic tape used. Conformance to this requirement must be demonstrated using a device that has time-averaging properties equivalent to those of the spectrum analyzer.

A36.3.6.5 For all appropriate level ranges and for steady sinusoidal electrical signals applied to the input of the measurement system, including all parts of the microphone system except the microphone, at one-third-octave nominal midband frequencies of 50 Hz, 1 kHz and 10 kHz, and the calibration check frequency, if it is not one of these frequencies, the level non-linearity must not exceed  $\pm 0.5$  dB for a linear operating range of at least 50 dB below the upper boundary of the level range.

Note 1: Level linearity of measurement system components may be tested according to the methods described in IEC 61265 as amended.

Note 2: Microphone extension cables configured in the field need not be included for the level linearity determination.

A36.3.6.6 On the reference level range, the level corresponding to the calibration sound pressure level must be at least 5 dB, but no more than 30 dB less than the upper boundary of the level range.

A36.3.6.7 The linear operating ranges on adjacent level ranges must overlap by at least 50 dB minus the change in attenuation introduced by a change in the level range controls.

Note: It is possible for a measurement system to have level range controls that permit attenuation changes of either 10 dB or 1 dB, for example. With 10 dB steps, the minimum overlap required would be 40 dB, and with 1 dB steps the minimum overlap would be 49 dB.

A36.3.6.8 An overload indicator must be included in the recording and reproducing systems so that an overload indication will occur during an overload condition on any relevant level range.

A36.3.6.9 Attenuators included in the measurement system to permit range changes must operate

in known intervals of decibel steps.

#### A36.3.7 *Analysis systems.*

A36.3.7.1 The analysis system must conform to the specifications in sections A36.3.7.2 to A36.3.7.7 for the frequency bandwidths, channel configurations and gain settings used for analysis.

A36.3.7.2 The output of the analysis system must consist of one-third octave band sound pressure levels as a function of time, obtained by processing the noise signals (preferably recorded) through an analysis system with the following characteristics:

- (a) A set of 24 one-third octave band filters, or their equivalent, having nominal midband frequencies from 50 Hz to 10 kHz inclusive;
- (b) Response and averaging properties in which, in principle, the output from any one-third octave filter band is squared, averaged and displayed or stored as time-averaged sound pressure levels;
- (c) The interval between successive sound pressure level samples must be 500 ms  $\pm$ 5 milliseconds(ms) for spectral analysis with or without slow time-weighting, as defined in section A36.3.7.4;
- (d) For those analysis systems that do not process the sound pressure signals during the period of time required for readout and/or resetting of the analyzer, the loss of data must not exceed a duration of 5 ms; and
- (e) The analysis system must operate in real time from 50 Hz through at least 12 kHz inclusive. This requirement applies to all operating channels of a multi-channel spectral analysis system.

A36.3.7.3 The minimum standard for the one-third octave band analysis system is the class 2 electrical performance requirements of IEC 61260 as amended, over the range of one-third octave nominal midband frequencies from 50 Hz through 10 kHz inclusive.

Note: IEC 61260 specifies procedures for testing of one-third octave band analysis systems for relative attenuation, anti-aliasing filters, real time operation, level linearity, and filter integrated response (effective bandwidth).

A36.3.7.4 When slow time averaging is performed in the analyzer, the response of the one-third octave band analysis system to a sudden onset or interruption of a constant sinusoidal signal at the respective one-third octave nominal midband frequency, must be measured at sampling instants 0.5, 1, 1.5 and 2 seconds(s) after the onset and 0.5 and 1s after interruption. The rising response must be  $-4 \pm 1$  dB at 0.5s,  $-1.75 \pm 0.75$  dB at 1s,  $-1 \pm 0.5$  dB at 1.5s and  $-0.5 \pm 0.5$  dB at 2s relative to the steady-state level. The falling response must be such that the sum of the output signal levels, relative to the initial steady-state level, and the corresponding rising response reading is  $-6.5 \pm 1$  dB, at both 0.5 and 1s. At subsequent times the sum of the rising and falling responses must be  $-7.5$  dB or less. This equates to an exponential averaging process (slow time-weighting) with a nominal 1s time

constant ( *i.e.*, 2s averaging time).

A36.3.7.5 When the one-third octave band sound pressure levels are determined from the output of the analyzer without slow time-weighting, slow time-weighting must be simulated in the subsequent processing. Simulated slow time-weighted sound pressure levels can be obtained using a continuous exponential averaging process by the following equation:

$$L_s(i,k)=10 \log [(0.60653) 100.1 L_s[i, (k-1)]+ (0.39347) 100.1 L (i, k)]$$

where  $L_s(i,k)$  is the simulated slow time-weighted sound pressure level and  $L(i,k)$  is the as-measured 0.5s time average sound pressure level determined from the output of the analyzer for the k-th instant of time and i-th one-third octave band. For  $k=1$ , the slow time-weighted sound pressure  $L_s[i, (k-1=0)]$  on the right hand side should be set to 0 dB. An approximation of the continuous exponential averaging is represented by the following equation for a four sample averaging process for  $k \geq 4$ :

$$L_s(i,k)=10 \log [(0.13) 100.1 L[i,(k-3)]+ (0.21) 100.1 L[i, (k-2)]+ (0.27) 100.1 L[i, (k-1)]+ (0.39) 100.1 L[i, k]]$$

where  $L_s(i, k)$  is the simulated slow time-weighted sound pressure level and  $L (i, k)$  is the as measured 0.5s time average sound pressure level determined from the output of the analyzer for the k-th instant of time and the i-th one-third octave band.

The sum of the weighting factors is 1.0 in the two equations. Sound pressure levels calculated by means of either equation are valid for the sixth and subsequent 0.5s data samples, or for times greater than 2.5s after initiation of data analysis.

Note: The coefficients in the two equations were calculated for use in determining equivalent slow time-weighted sound pressure levels from samples of 0.5s time average sound pressure levels. The equations do not work with data samples where the averaging time differs from 0.5s.

A36.3.7.6 The instant in time by which a slow time-weighted sound pressure level is characterized must be 0.75s earlier than the actual readout time.

Note: The definition of this instant in time is needed to correlate the recorded noise with the aircraft position when the noise was emitted and takes into account the averaging period of the slow time-weighting. For each 0.5 second data record this instant in time may also be identified as 1.25 seconds after the start of the associated 2 second averaging period.

A36.3.7.7 The resolution of the sound pressure levels, both displayed and stored, must be 0.1 dB or finer.

A36.3.8 *Calibration systems.*

A36.3.8.1 The acoustical sensitivity of the measurement system must be determined using a sound calibrator generating a known sound pressure level at a known frequency. The minimum standard for the sound calibrator is the class 1L requirements of IEC 60942 as amended.

### A36.3.9 *Calibration and checking of system.*

A36.3.9.1 Calibration and checking of the measurement system and its constituent components must be carried out to the satisfaction of the FAA by the methods specified in sections A36.3.9.2 through A36.3.9.10. The calibration adjustments, including those for environmental effects on sound calibrator output level, must be reported to the FAA and applied to the measured one-third-octave sound pressure levels determined from the output of the analyzer. Data collected during an overload indication are invalid and may not be used. If the overload condition occurred during recording, the associated test data are invalid, whereas if the overload occurred during analysis, the analysis must be repeated with reduced sensitivity to eliminate the overload.

A36.3.9.2 The free-field frequency response of the microphone system may be determined by use of an electrostatic actuator in combination with manufacturer's data or by tests in an anechoic free-field facility. The correction for frequency response must be determined within 90 days of each test series. The correction for non-uniform frequency response of the microphone system must be reported to the FAA and applied to the measured one-third octave band sound pressure levels determined from the output of the analyzer.

A36.3.9.3 When the angles of incidence of sound emitted from the aircraft are within  $\pm 30^\circ$  of grazing incidence at the microphone (see Figure A36-1), a single set of free-field corrections based on grazing incidence is considered sufficient for correction of directional response effects. For other cases, the angle of incidence for each 0.5 second sample must be determined and applied for the correction of incidence effects.

A36.3.9.4 For analog magnetic tape recorders, each reel of magnetic tape must carry at least 30 seconds of pink random or pseudo-random noise at its beginning and end. Data obtained from analog tape-recorded signals will be accepted as reliable only if level differences in the 10 kHz one-third-octave-band are not more than 0.75 dB for the signals recorded at the beginning and end.

A36.3.9.5 The frequency response of the entire measurement system while deployed in the field during the test series, exclusive of the microphone, must be determined at a level within 5 dB of the level corresponding to the calibration sound pressure level on the level range used during the tests for each one-third octave nominal midband frequency from 50 Hz to 10 kHz inclusive, utilizing pink random or pseudo-random noise. Within six months of each test series the output of the noise generator must be determined by a method traceable to the U.S. National Institute of Standards and Technology or to an equivalent national standards laboratory as determined by the FAA. Changes in the relative output from the previous calibration at each one-third octave band may not exceed 0.2 dB. The correction for frequency response must be reported to the FAA and applied to the measured one-third octave sound pressure levels determined from the output of the analyzer.

A36.3.9.6 The performance of switched attenuators in the equipment used during noise certification measurements and calibration must be checked within six months of each test series to ensure that the maximum error does not exceed 0.1 dB.

A36.3.9.7 The sound pressure level produced in the cavity of the coupler of the sound calibrator must be calculated for the test environmental conditions using the manufacturer's supplied



information on the influence of atmospheric air pressure and temperature. This sound pressure level is used to establish the acoustical sensitivity of the measurement system. Within six months of each test series the output of the sound calibrator must be determined by a method traceable to the U.S. National Institute of Standards and Technology or to an equivalent national standards laboratory as determined by the FAA. Changes in output from the previous calibration must not exceed 0.2 dB.

A36.3.9.8 Sufficient sound pressure level calibrations must be made during each test day to ensure that the acoustical sensitivity of the measurement system is known at the prevailing environmental conditions corresponding with each test series. The difference between the acoustical sensitivity levels recorded immediately before and immediately after each test series on each day may not exceed 0.5 dB. The 0.5 dB limit applies after any atmospheric pressure corrections have been determined for the calibrator output level. The arithmetic mean of the before and after measurements must be used to represent the acoustical sensitivity level of the measurement system for that test series. The calibration corrections must be reported to the FAA and applied to the measured one-third octave band sound pressure levels determined from the output of the analyzer.

A36.3.9.9 Each recording medium, such as a reel, cartridge, cassette, or diskette, must carry a sound pressure level calibration of at least 10 seconds duration at its beginning and end.

A36.3.9.10 The free-field insertion loss of the windscreen for each one-third octave nominal midband frequency from 50 Hz to 10 kHz inclusive must be determined with sinusoidal sound signals at the incidence angles determined to be applicable for correction of directional response effects per section A36.3.9.3. The interval between angles tested must not exceed 30 degrees. For a windscreen that is undamaged and uncontaminated, the insertion loss may be taken from manufacturer's data. Alternatively, within six months of each test series the insertion loss of the windscreen may be determined by a method traceable to the U.S. National Institute of Standards and Technology or an equivalent national standards laboratory as determined by the FAA. Changes in the insertion loss from the previous calibration at each one-third-octave frequency band must not exceed 0.4 dB. The correction for the free-field insertion loss of the windscreen must be reported to the FAA and applied to the measured one-third octave sound pressure levels determined from the output of the analyzer.

#### *A36.3.10 Adjustments for ambient noise.*

A36.3.10.1 Ambient noise, including both an acoustical background and electrical noise of the measurement system, must be recorded for at least 10 seconds at the measurement points with the system gain set at the levels used for the aircraft noise measurements. Ambient noise must be representative of the acoustical background that exists during the flyover test run. The recorded aircraft noise data is acceptable only if the ambient noise levels, when analyzed in the same way, and quoted in PNL (see A36.4.1.3 (a)), are at least 20 dB below the maximum PNL of the aircraft.

A36.3.10.2 Aircraft sound pressure levels within the 10 dB-down points (see A36.4.5.1) must exceed the mean ambient noise levels determined in section A36.3.10.1 by at least 3 dB in each one-third octave band, or must be adjusted using a method approved by the FAA; one

method is described in the current advisory circular for this part.

#### *Section A36.4 Calculation of Effective Perceived Noise Level From Measured Data*

##### *A36.4.1 General.*

A36.4.1.1 The basic element for noise certification criteria is the noise evaluation measure known as effective perceived noise level, EPNL, in units of EPNdB, which is a single number evaluator of the subjective effects of airplane noise on human beings. EPNL consists of instantaneous perceived noise level, PNL, corrected for spectral irregularities, and for duration. The spectral irregularity correction, called “tone correction factor”, is made at each time increment for only the maximum tone.

A36.4.1.2 Three basic physical properties of sound pressure must be measured: level, frequency distribution, and time variation. To determine EPNL, the instantaneous sound pressure level in each of the 24 one-third octave bands is required for each 0.5 second increment of time during the airplane noise measurement.

A36.4.1.3 The calculation procedure that uses physical measurements of noise to derive the EPNL evaluation measure of subjective response consists of the following five steps:

- (a) The 24 one-third octave bands of sound pressure level are converted to perceived noisiness (noy) using the method described in section A36.4.2.1 (a). The noy values are combined and then converted to instantaneous perceived noise levels, PNL(k).
- (b) A tone correction factor C(k) is calculated for each spectrum to account for the subjective response to the presence of spectral irregularities.
- (c) The tone correction factor is added to the perceived noise level to obtain tone-corrected perceived noise levels PNLT(k), at each one-half second increment:

$$\text{PNLT}(k) = \text{PNL}(k) + C(k)$$

The instantaneous values of tone-corrected perceived noise level are derived and the maximum value, PNLTM, is determined.

- (d) A duration correction factor, D, is computed by integration under the curve of tone-corrected perceived noise level versus time.
- (e) Effective perceived noise level, EPNL, is determined by the algebraic sum of the maximum tone-corrected perceived noise level and the duration correction factor:

$$\text{EPNL} = \text{PNLTM} + D$$

##### *A36.4.2 Perceived noise level.*

A36.4.2.1 Instantaneous perceived noise levels, PNL(k), must be calculated from instantaneous one-third octave band sound pressure levels, SPL(i, k) as follows:

- (a) Step 1: For each one-third octave band from 50 through 10,000 Hz, convert SPL(i, k) to perceived noisiness n(i, k), by using the mathematical formulation of the noy table given in section A36.4.7.
- (b) Step 2: Combine the perceived noisiness values, n(i, k), determined in step 1 by using the following formula:

$$N(k) = n(k) + 0.15 \left\{ \left[ \sum_{i=1}^{24} n(i, k) \right] - n(k) \right\}$$

$$= 0.85 n(k) + 0.15 \sum_{i=1}^{24} n(i, k)$$

where n(k) is the largest of the 24 values of n(i, k) and N(k) is the total perceived noisiness.

- (c) Step 3: Convert the total perceived noisiness, N(k), determined in Step 2 into perceived noise level, PNL(k), using the following formula:

$$PNL(k) = 40.0 + \frac{10}{\log 2} \log N(k)$$

Note: PNL(k) is plotted in the current advisory circular for this part.

### A36.4.3 Correction for spectral irregularities.

A36.4.3.1 Noise having pronounced spectral irregularities (for example, the maximum discrete frequency components or tones) must be adjusted by the correction factor C(k) calculated as follows:

- (a) Step 1: After applying the corrections specified under section A36.3.9, start with the sound pressure level in the 80 Hz one-third octave band (band number 3), calculate the changes in sound pressure level (or “slopes”) in the remainder of the one-third octave bands as follows:

$$s(3, k) = \text{no value}$$

$$s(4, k) = \text{SPL}(4, k) - \text{SPL}(3, k)$$

•

•

$$s(i, k) = \text{SPL}(i, k) - \text{SPL}(i-1, k)$$

•

•

$$s(24, k) = \text{SPL}(24, k) - \text{SPL}(23, k)$$

(b) Step 2: Encircle the value of the slope,  $s(i, k)$ , where the absolute value of the change in slope is greater than five; that is where:

$$|\Delta s(i, k)| = |s(i, k) - s(i-1, k)| > 5$$

(c) Step 3:

(1) If the encircled value of the slope  $s(i, k)$  is positive and algebraically greater than the slope  $s(i-1, k)$  encircle  $\text{SPL}(i, k)$ .

(2) If the encircled value of the slope  $s(i, k)$  is zero or negative and the slope  $s(i-1, k)$  is positive, encircle  $\text{SPL}(i-1, k)$ .

(3) For all other cases, no sound pressure level value is to be encircled.

(d) Step 4: Compute new adjusted sound pressure levels  $\text{SPL}'(i, k)$  as follows:

(1) For non-encircled sound pressure levels, set the new sound pressure levels equal to the original sound pressure levels,  $\text{SPL}'(i, k) = \text{SPL}(i, k)$ .

(2) For encircled sound pressure levels in bands 1 through 23 inclusive, set the new sound pressure level equal to the arithmetic average of the preceding and following sound pressure levels as shown below:

$$\text{SPL}'(i, k) = 1/2[\text{SPL}(i-1, k) + \text{SPL}(i+1, k)]$$

(3) If the sound pressure level in the highest frequency band ( $i=24$ ) is encircled, set the new sound pressure level in that band equal to:

$$\text{SPL}'(24, k) = \text{SPL}(23, k) + s(23, k)$$

(e) Step 5: Recompute new slope  $s'(i, k)$ , including one for an imaginary 25th band, as follows:

$$s'(3, k) = s'(4, k)$$

$$s'(4, k) = \text{SPL}'(4, k) - \text{SPL}'(3, k)$$

•

•

$$s'(i, k) = \text{SPL}'(i, k) - \text{SPL}'(i-1, k)$$

•

•

$$s'(24, k) = \text{SPL}'(24, k) - \text{SPL}'(23, k)$$

$$s'(25, k) = s'(24, k)$$

(f) Step 6: For  $i$ , from 3 through 23, compute the arithmetic average of the three adjacent slopes as follows:

$$s(i, k) = 1/3 [s'(i, k) + s'(i+1, k) + s'(i+2, k)]$$

(g) Step 7: Compute final one-third octave-band sound pressure levels,  $\text{SPL}'(i, k)$ , by beginning with band number 3 and proceeding to band number 24 as follows:

$$\text{SPL}'(3, k) = \text{SPL}(3, k)$$

$$\text{SPL}'(4, k) = \text{SPL}'(3, k) + s(3, k)$$

•

•

$$\text{SPL}'(i, k) = \text{SPL}'(i-1, k) + s(i-1, k)$$

•

•

$$\text{SPL}'(24, k) = \text{SPL}'(23, k) + s(23, k)$$

(h) Step 8: Calculate the differences,  $F(i, k)$ , between the original sound pressure level and the final background sound pressure level as follows:

$$F(i, k) = \text{SPL}(i, k) - \text{SPL}'(i, k)$$

and note only values equal to or greater than 1.5.

(i) Step 9: For each of the relevant one-third octave bands (3 through 24), determine tone correction factors from the sound pressure level differences  $F(i, k)$  and Table A36-2.

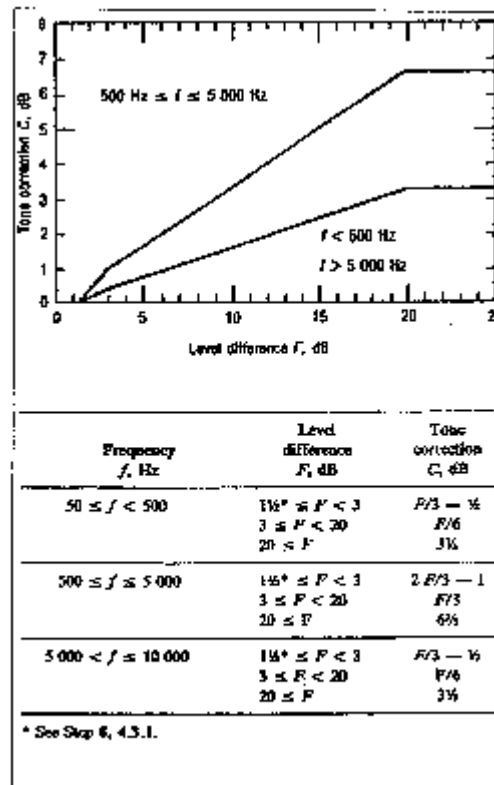

Table A.36-2. Tone correction factor

[View or download PDF](#)

- (j) Step 10: Designate the largest of the tone correction factors, determined in Step 9, as  $C(k)$ . (An example of the tone correction procedure is given in the current advisory circular for this part). Tone-corrected perceived noise levels  $PNLT(k)$  must be determined by adding the  $C(k)$  values to corresponding  $PNL(k)$  values, that is:

$$PNLT(k) = PNL(k) + C(k)$$

For any  $i$ -th one-third octave band, at any  $k$ -th increment of time, for which the tone correction factor is suspected to result from something other than (or in addition to) an actual tone (or any spectral irregularity other than airplane noise), an additional analysis may be made using a filter with a bandwidth narrower than one-third of an octave. If the narrow band analysis corroborates these suspicions, then a revised value for the background sound pressure level  $SPL'(i,k)$ , may be determined from the narrow band analysis and used to compute a revised tone correction factor for that particular one-third octave band. Other methods of rejecting spurious tone corrections may be approved.

A36.4.3.2 The tone correction procedure will underestimate EPNL if an important tone is of a frequency such that it is recorded in two adjacent one-third octave bands. An applicant must demonstrate that either:

- (a) No important tones are recorded in two adjacent one-third octave bands; or
- (b) That if an important tone has occurred, the tone correction has been adjusted to the value it

would have had if the tone had been recorded fully in a single one-third octave band.

A36.4.4 Maximum tone-corrected perceived noise level

A36.4.4.1 The maximum tone-corrected perceived noise level, PNLTM, must be the maximum calculated value of the tone-corrected perceived noise level PNLT(k). It must be calculated using the procedure of section A36.4.3. To obtain a satisfactory noise time history, measurements must be made at 0.5 second time intervals.

Note 1: Figure A36–2 is an example of a flyover noise time history where the maximum value is clearly indicated.

Note 2: In the absence of a tone correction factor, PNLTM would equal PNLM.

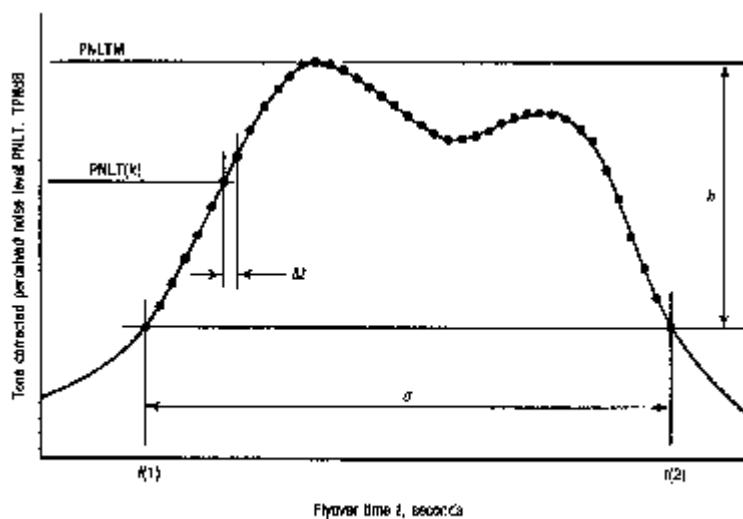

Figure A36-2. Example of perceived noise level corrected for tones as a function of aircraft flyover time

[View or download PDF](#)

A36.4.4.2 After the value of PNLTM is obtained, the frequency band for the largest tone correction factor is identified for the two preceding and two succeeding 500 ms data samples. This is performed in order to identify the possibility of tone suppression at PNLTM by one-third octave band sharing of that tone. If the value of the tone correction factor C(k) for PNLTM is less than the average value of C(k) for the five consecutive time intervals, the average value of C(k) must be used to compute a new value for PNLTM.

A36.4.5 Duration correction.

A36.4.5.1 The duration correction factor D determined by the integration technique is defined by the expression:

$$D = 10 \log \left[ \left( \frac{1}{T} \right)^{t(2)} \int_{t(1)}^{t(2)} \text{antilog} \frac{\text{PNLT}}{10} dt \right] - \text{PNLTM}$$

where T is a normalizing time constant, PNLTM is the maximum value of PNLT, t(1) is the first point of time after which PNLT becomes greater than PNLTM–10, and t(2) is the point of time after which PNLT remains constantly less than PNLTM–10.

A36.4.5.2 Since PNLT is calculated from measured values of sound pressure level (SPL), there is no obvious equation for PNLT as a function of time. Consequently, the equation is to be rewritten with a summation sign instead of an integral sign as follows:

$$D = 10 \log \left[ \left( \frac{1}{T} \right) \sum_{k=0}^{d/\Delta t} \Delta t \cdot \text{antilog} \frac{\text{PNLT}(k)}{10} \right] - \text{PNLTM}$$

where  $\Delta t$  is the length of the equal increments of time for which PNLT(k) is calculated and d is the time interval to the nearest 0.5s during which PNLT(k) remains greater or equal to PNLTM–10.

A36.4.5.3 To obtain a satisfactory history of the perceived noise level use one of the following:

- (a) Half-Second time intervals for  $\Delta t$ ; or
- (b) A shorter time interval with approved limits and constants.

A36.4.5.4 The following values for T and  $\Delta t$  must be used in calculating D in the equation given in section A36.4.5.2:

T=10 s, and

$\Delta t=0.5s$  (or the approved sampling time interval).

Using these values, the equation for D becomes:

$$D = 10 \log \left[ \sum_{k=0}^{2d} \text{antilog} \frac{\text{PNLT}(k)}{10} \right] - \text{PNLTM} - 13$$

where d is the duration time defined by the points corresponding to the values PNLTM–10.

A36.4.5.5 If in using the procedures given in section A36.4.5.2, the limits of PNLTM–10 fall between the calculated PNLT(k) values (the usual case), the PNLT(k) values defining the limits of the duration interval must be chosen from the PNLT(k) values closest to PNLTM–10. For those cases with more than one peak value of PNLT(k), the applicable limits must be chosen to yield the largest possible value for the duration time.

A36.4.6 *Effective perceived noise level.*

The total subjective effect of an airplane noise event, designated effective perceived noise level, EPNL, is equal to the algebraic sum of the maximum value of the tone-corrected perceived noise level, PNLTM, and the duration correction D. That is:



$$EPNL = PNLTM + D$$

where PNLTM and D are calculated using the procedures given in sections A36.4.2, A36.4.3, A36.4.4. and A36.4.5.

#### A36.4.7 *Mathematical formulation of noy tables.*

A36.4.7.1 The relationship between sound pressure level (SPL) and the logarithm of perceived noisiness is illustrated in Figure A36–3 and Table A36–3.

A36.4.7.2 The bases of the mathematical formulation are:

- (a) The slopes (M(b), M(c), M(d) and M(e)) of the straight lines;
- (b) The intercepts (SPL(b) and SPL(c)) of the lines on the SPL axis; and
- (c) The coordinates of the discontinuities, SPL(a) and  $\log n(a)$ ; SPL(d) and  $\log n = -1.0$ ; and SPL(e) and  $\log n = \log(0.3)$ .

A36.4.7.3 Calculate noy values using the following equations:

(a)

$$SPL \geq SPL(a)$$

$$n = \text{antilog} \{ (c)[SPL - SPL(c)] \}$$

(b)

$$SPL(b) \leq SPL < SPL(a)$$

$$n = \text{antilog} \{ M(b)[SPL - SPL(b)] \}$$

(c)

$$SPL(e) \leq SPL < SPL(b)$$

$$n = 0.3 \text{ antilog} \{ M(e)[SPL - SPL(e)] \}$$

(d)

$$SPL(d) \leq SPL < SPL(e)$$

$$n = 0.1 \text{ antilog} \{ M(d)[SPL - SPL(d)] \}$$

A36.4.7.4 Table A36–3 lists the values of the constants necessary to calculate perceived noisiness as a function of sound pressure level.

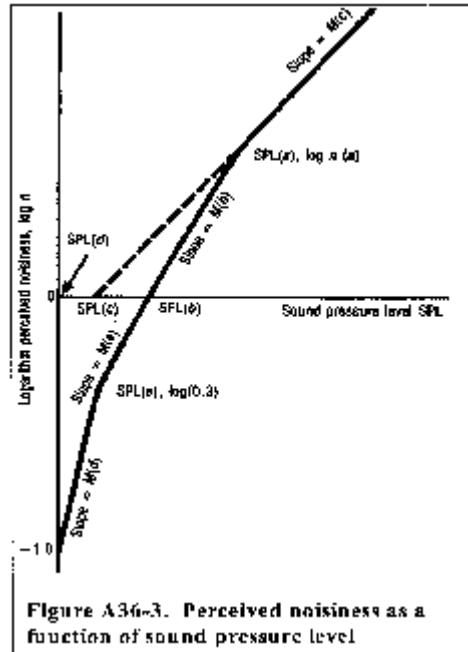

[View or download PDF](#)

BAND (i)	f HZ	SPL (a)	SPL (b)	SPL (c)	SPL (d)	SPL (e)	M(f)	M(c)	M(d)	M(e)
1	50	91.0	64	52	49	55	0.043478	0.030103	0.079520	0.058098
2	63	85.9	60	51	44	51	0.040570		0.068160	"
3	80	87.3	56	49	39	46	0.036831		"	0.052288
4	100	79.9	53	47	34	42	"		0.059640	0.047534
5	125	79.8	51	46	30	39	0.035336		0.053013	0.043573
6	160	76.0	48	45	27	36	0.033333			"
7	200	74.0	46	43	24	33	"			0.040221
8	250	74.9	44	42	21	30	0.032051			0.037349
9	315	94.6	42	41	18	27	0.030675	0.030103		0.034859
10	400		40	40	16	25	0.030103			
11	500		40	40	16	25				
12	630		40	40	16	25				
13	800		40	40	16	25				
14	1 000		40	40	16	25			0.063013	
15	1 250		38	38	15	23	0.030103		0.059640	0.034859
16	1 600		34	34	12	21	0.029960		0.053013	0.040221
17	2 000		32	32	9	18			"	0.037349
18	2 500		30	30	5	15			0.047712	0.034859
19	3 150		29	29	4	14			"	
20	4 000		29	29	5	14			0.053013	
21	5 000		30	30	6	15			"	0.034859
22	6 300		31	31	10	17	0.029960		0.068160	0.037349
23	8 000	44.3	37	34	17	23	0.042285	0.029960	0.079520	"
24	10 000	50.7	41	37	21	29	"	"	0.059640	0.043573

Table A36-3. Constants for mathematically formulated noise values

[View or download PDF](#)

### *Section A36.5 Reporting of Data to the FAA*

#### *A36.5.1 General.*

A36.5.1.1 Data representing physical measurements and data used to make corrections to physical measurements must be recorded in an approved permanent form and appended to the record.

A36.5.1.2 All corrections must be reported to and approved by the FAA, including corrections to measurements for equipment response deviations.

A36.5.1.3 Applicants may be required to submit estimates of the individual errors inherent in each of the operations employed in obtaining the final data.

#### *A36.5.2 Data reporting.*

An applicant is required to submit a noise certification compliance report that includes the following.

A36.5.2.1 The applicant must present measured and corrected sound pressure levels in one-third octave band levels that are obtained with equipment conforming to the standards described in section A36.3 of this appendix.

A36.5.2.2 The applicant must report the make and model of equipment used for measurement and analysis of all acoustic performance and meteorological data.

A36.5.2.3 The applicant must report the following atmospheric environmental data, as measured immediately before, after, or during each test at the observation points prescribed in section A36.2 of this appendix.

- (a) Air temperature and relative humidity;
- (b) Maximum, minimum and average wind velocities; and
- (c) Atmospheric pressure.

A36.5.2.4 The applicant must report conditions of local topography, ground cover, and events that might interfere with sound recordings.

A36.5.2.5 The applicant must report the following:

- (a) Type, model and serial numbers (if any) of airplane, engine(s), or propeller(s) (as applicable);
- (b) Gross dimensions of airplane and location of engines;
- (c) Airplane gross weight for each test run and center of gravity range for each series of test runs;

- (d) Airplane configuration such as flap, airbrakes and landing gear positions for each test run;
- (e) Whether auxiliary power units (APU), when fitted, are operating for each test run;
- (f) Status of pneumatic engine bleeds and engine power take-offs for each test run;
- (g) Indicated airspeed in knots or kilometers per hour for each test run;
- (h) Engine performance data:
  - (1) For jet airplanes: engine performance in terms of net thrust, engine pressure ratios, jet exhaust temperatures and fan or compressor shaft rotational speeds as determined from airplane instruments and manufacturer's data for each test run;
  - (2) For propeller-driven airplanes: engine performance in terms of brake horsepower and residual thrust; or equivalent shaft horsepower; or engine torque and propeller rotational speed; as determined from airplane instruments and manufacturer's data for each test run;
- (i) Airplane flight path and ground speed during each test run; and
- (j) The applicant must report whether the airplane has any modifications or non-standard equipment likely to affect the noise characteristics of the airplane. The FAA must approve any such modifications or non-standard equipment.

#### A36.5.3 *Reporting of noise certification reference conditions.*

A36.5.3.1 Airplane position and performance data and the noise measurements must be corrected to the noise certification reference conditions specified in the relevant sections of appendix B of this part. The applicant must report these conditions, including reference parameters, procedures and configurations.

#### A36.5.4 *Validity of results.*

A36.5.4.1 Three average reference EPNL values and their 90 percent confidence limits must be produced from the test results and reported, each such value being the arithmetical average of the adjusted acoustical measurements for all valid test runs at each measurement point (flyover, lateral, or approach). If more than one acoustic measurement system is used at any single measurement location, the resulting data for each test run must be averaged as a single measurement. The calculation must be performed by:

- (a) Computing the arithmetic average for each flight phase using the values from each microphone point; and
- (b) Computing the overall arithmetic average for each reference condition (flyover, lateral or approach) using the values in paragraph (a) of this section and the related 90 percent confidence limits.

A36.5.4.2 For each of the three certification measuring points, the minimum sample size is six. The sample size must be large enough to establish statistically for each of the three average

noise certification levels a 90 percent confidence limit not exceeding  $\pm 1.5$  EPNdB. No test result may be omitted from the averaging process unless approved by the FAA.

Note: Permitted methods for calculating the 90 percent confidence interval are shown in the current advisory circular for this part.

A36.5.4.3 The average EPNL figures obtained by the process described in section A36.5.4.1 must be those by which the noise performance of the airplane is assessed against the noise certification criteria.

*Section A36.6 Nomenclature: Symbols and Units*

Symbol	Unit	Meaning
antilog		Antilogarithm to the base 10.
C(k)	dB	<i>Tone correction factor.</i> The factor to be added to PNL(k) to account for the presence of spectral irregularities such as tones at the k-th increment of time.
D	s	<i>Duration time.</i> The time interval between the limits of t(1) and t(2) to the nearest 0.5 second.
D	dB	<i>Duration correction.</i> The factor to be added to PNLTM to account for the duration of the noise.
EPNL	EPNdB	<i>Effective perceived noise level.</i> The value of PNL adjusted for both spectral irregularities and duration of the noise. (The unit EPNdB is used instead of the unit dB).
EPNL <sub>r</sub>	EPNdB	Effective perceived noise level adjusted for reference conditions.
f(i)	Hz	<i>Frequency.</i> The geometrical mean frequency for the i-th one-third octave band.
F (i, k)	dB	<i>Delta-dB.</i> The difference between the original sound pressure level and the final background sound pressure level in the i-th one-third octave band at the k-th interval of time. In this case, background sound pressure level means the broadband noise level that would be present in the one-third octave band in the absence of the tone.
H	dB	<i>dB-down.</i> The value to be subtracted from PNLTM that defines the duration of the noise.
H	Percent	<i>Relative humidity.</i> The ambient atmospheric relative humidity.
I		<i>Frequency band index.</i> The numerical indicator that denotes any one of the 24 one-third octave bands with geometrical mean frequencies from 50 to 10,000 Hz.
K		<i>Time increment index.</i> The numerical indicator that denotes the number of equal time increments that have elapsed from a reference zero.
Log		Logarithm to the base 10.

log n(a)		<i>Noy discontinuity coordinate.</i> The log n value of the intersection point of the straight lines representing the variation of SPL with log n.
M(b),M(c), etc		<i>Noy inverse slope.</i> The reciprocals of the slopes of straight lines representing the variation of SPL with log n.
N	noy	The perceived noisiness at any instant of time that occurs in a specified frequency range.
n(i,k)	noy	The perceived noisiness at the k-th instant of time that occurs in the i-th one-third octave band.
n(k)	noy	<i>Maximum perceived noisiness.</i> The maximum value of all of the 24 values of n(i) that occurs at the k-th instant of time.
N(k)	noy	<i>Total perceived noisiness.</i> The total perceived noisiness at the k-th instant of time calculated from the 24-instantaneous values of n (i, k).
p(b), p(c), etc		<i>Noy slope.</i> The slopes of straight lines representing the variation of SPL with log n.
PNL	PNdB	The perceived noise level at any instant of time. (The unit PNdB is used instead of the unit dB).
PNL(k)	PNdB	The perceived noise level calculated from the 24 values of SPL (i, k), at the k-th increment of time. (The unit PNdB is used instead of the unit dB).
PNLM	PNdB	<i>Maximum perceived noise level.</i> The maximum value of PNL(k). (The unit PNdB is used instead of the unit dB).
PNLT	TPNdB	<i>Tone-corrected perceived noise level.</i> The value of PNL adjusted for the spectral irregularities that occur at any instant of time. (The unit TPNdB is used instead of the unit dB).
PNLT(k)	TPNdB	The tone-corrected perceived noise level that occurs at the k-th increment of time. PNLT(k) is obtained by adjusting the value of PNL(k) for the spectral irregularities that occur at the k-th increment of time. (The unit TPNdB is used instead of the unit dB).
PNLTM	TPNdB	<i>Maximum tone-corrected perceived noise level.</i> The maximum value of PNLT(k). (The unit TPNdB is used instead of the unit dB).
PNLT <sub>r</sub>	TPNdB	Tone-corrected perceived noise level adjusted for reference conditions.
s (i, k)	dB	<i>Slope of sound pressure level.</i> The change in level between adjacent one-third octave band sound pressure levels at the i-th band for the k-th instant of time.
Δs (i, k)	dB	Change in slope of sound pressure level.
s' (i, k)	dB	Adjusted slope of sound pressure level. The change in level between adjacent adjusted one-third octave band sound pressure levels at the i-th band for the k-th instant of time.
s (i, k)	dB	Average slope of sound pressure level.

SPL	dB	re 20 $\mu$ P a	<i>Sound pressure level.</i> The sound pressure level that occurs in a specified frequency range at any instant of time.
SPL(a)	dB	re 20 $\mu$ P a	<i>Noy discontinuity coordinate.</i> The SPL value of the intersection point of the straight lines representing the variation of SPL with log n.
SPL(b) SPL (c)	dB	re 20 $\mu$ P a	<i>Noy intercept.</i> The intercepts on the SPL-axis of the straight lines representing the variation of SPL with log n.
SPL (i, k)	dB	re 20 $\mu$ P a	The sound pressure level at the k-th instant of time that occurs in the i-th one-third octave band.
SPL' (i, k)	dB	re 20 $\mu$ P a	<i>Adjusted sound pressure level.</i> The first approximation to background sound pressure level in the i-th one-third octave band for the k-th instant of time.
SPL(i)	dB	re 20 $\mu$ P a	<i>Maximum sound pressure level.</i> The sound pressure level that occurs in the i-th one-third octave band of the spectrum for PNLTM.
SPL(i) <sub>r</sub>	dB	re 20 $\mu$ P a	<i>Corrected maximum sound pressure level.</i> The sound pressure level that occurs in the i-th one-third octave band of the spectrum for PNLTM corrected for atmospheric sound absorption.
SPL' (i, k)	dB	re 20 $\mu$ P a	<i>Final background sound pressure level.</i> The second and final approximation to background sound pressure level in the i-th one-third octave band for the k-th instant of time.
t	s		<i>Elapsed time.</i> The length of time measured from a reference zero.
t(1), t(2)	s		<i>Time limit.</i> The beginning and end, respectively, of the noise time history defined by h.
$\Delta$ t	s		<i>Time increment.</i> The equal increments of time for which PNL(k) and PNLT(k) are calculated.
T	s		<i>Normalizing time constant.</i> The length of time used as a reference in the integration method for computing duration corrections, where T=10s.
t(°F) (°C)	°F, °C		<i>Temperature.</i> The ambient air temperature.
$\alpha$ (i)	dB/1000ft		<i>Test atmospheric absorption.</i> The atmospheric attenuation of sound that

	db /1 00 m	occurs in the i-th one-third octave band at the measured air temperature and relative humidity.
$\alpha(i)_o$	dB/1000ft db /1 00 m	<i>Reference atmospheric absorption.</i> The atmospheric attenuation of sound that occurs in the i-th one-third octave band at a reference air temperature and relative humidity.
$A_1$	Degrees	First constant climb angle (Gear up, speed of at least $V_2+10$ kt ( $V_2+19$ km/h), takeoff thrust).
$A_2$	Degrees	Second constant climb angle (Gear up, speed of at least $V_2+10$ kt ( $V_2+19$ km/h), after cut-back).
$\delta$ $\epsilon$	Degrees	<i>Thrust cutback angles.</i> The angles defining the points on the takeoff flight path at which thrust reduction is started and ended respectively.
$\eta$	Degrees	Approach angle.
$\eta_r$	Degrees	Reference approach angle.
$\Theta$	Degrees	<i>Noise angle (relative to flight path).</i> The angle between the flight path and noise path. It is identical for both measured and corrected flight paths.
$\psi$	Degrees	<i>Noise angle (relative to ground).</i> The angle between the noise path and the ground. It is identical for both measured and corrected flight paths.
$\mu$		Engine noise emission parameter.
$\mu_r$		Reference engine noise emission parameter.
$\Delta_1$	EPNdB	<i>PNLT correction.</i> The correction to be added to the EPNL calculated from measured data to account for noise level changes due to differences in atmospheric absorption and noise path length between reference and test conditions.
$\Delta_2$	EPNdB	<i>Adjustment to duration correction.</i> The adjustment to be made to the EPNL calculated from measured data to account for noise level changes due to the noise duration between reference and test conditions.
$\Delta_3$	EPNdB	<i>Source noise adjustment.</i> The adjustment to be made to the EPNL calculated from measured data to account for noise level changes due to differences between reference and test engine operating conditions.

### Section A36.7 Sound Attenuation in Air

A36.7.1 The atmospheric attenuation of sound must be determined in accordance with the procedure presented in section A36.7.2.



A36.7.2 The relationship between sound attenuation, frequency, temperature, and humidity is expressed by the following equations.

A36.7.2(a) For calculations using the English System of Units:

$$\alpha(i) = 10^{[2.05 \log(f_0/1000) + 6.33 \times 10^{-4} \rho - 14.5325]} + \eta(\delta) \times 10^{[\log(f_0) + 4.6883 \times 10^{-3} \rho - 2.4215]}$$

and

$$\delta = \sqrt{\frac{1010}{F(0)}} 10^{(\%H - 1.97274664 + 2.288074 \times 10^{-2} \rho)} \times 10^{(-9.389 \times 10^{-5} \rho^2 + 3.0 \times 10^{-9} \rho^3)}$$

where

$\eta(\delta)$  is listed in Table A36–4 and  $f_0$  in Table A36–5;

$\alpha(i)$  is the attenuation coefficient in dB/1000 ft;

$\Theta$  is the temperature in °F; and

H is the relative humidity, expressed as a percentage.

A36.7.2(b) For calculations using the International System of Units (SI):

$$\alpha(i) = 10^{[2.05 \log(f_0/1000) + 1.1394 \times 10^{-3} \rho - 1.916984]} + \eta(\delta) \times 10^{[\log(f_0) + 8.42994 \times 10^{-3} \rho - 2.755624]}$$

and

$$\delta = \sqrt{\frac{1010}{F_0}} 10^{(\log H - 1.328924 + 3.179768 \times 10^{-2} \rho)} \times 10^{(-2.173716 \times 10^{-4} \rho^2 + 1.7496 \times 10^{-6} \rho^3)}$$

where

$\eta(\delta)$  is listed in Table A36–4 and  $f_0$  in Table A36–5;

$\alpha(i)$  is the attenuation coefficient in dB/100 m;

$\Theta$  is the temperature in °C; and

H is the relative humidity, expressed as a percentage.

A36.7.3 The values listed in table A36-4 are to be used when calculating the equations listed in section A36.7.2. A term of quadratic interpolation is to be used where necessary.

*Section A36.8 [Reserved]*

Table A36-4. Values of  $\eta(\delta)$

$\delta$	$\eta(\delta)$	$\delta$	$\eta(\delta)$
0.00	0.000	2.50	0.450
0.25	0.315	2.80	0.400
0.50	0.700	3.00	0.370
0.60	0.840	3.30	0.330
0.70	0.930	3.60	0.300
0.80	0.975	4.15	0.260
0.90	0.996	4.15	0.245
1.00	1.000	4.80	0.230
1.10	0.970	5.25	0.220
1.20	0.900	5.70	0.210
1.30	0.840	6.05	0.205
1.50	0.750	6.50	0.200
1.70	0.670	7.00	0.200
2.00	0.570	10.00	0.200
2.30	0.495		

Table A36-5. Values of  $f_0$

one-third octave center frequency	$f_0$ (Hz)	one third octave center frequency	$f_0$ (Hz)
50	50	800	800
63	63	1000	1000
80	80	1250	1250
100	100	1600	1600
125	125	2000	2000
160	160	2500	2500
200	200	3150	3150
250	250	4000	4000
315	315	5000	4500
400	400	6300	5600
500	500	8000	7100
630	630	10000	9000

*Section A36.9 Adjustment of Airplane Flight Test Results.*

A36.9.1 When certification test conditions are not identical to reference conditions, appropriate adjustments must be made to the measured noise data using the methods described in this section.

A36.9.1.1 Adjustments to the measured noise values must be made using one of the methods described in sections A36.9.3 and A36.9.4 for differences in the following:

- (a) Attenuation of the noise along its path as affected by “inverse square” and atmospheric attenuation

- (b) Duration of the noise as affected by the distance and the speed of the airplane relative to the measuring point
- (c) Source noise emitted by the engine as affected by the differences between test and reference engine operating conditions
- (d) Airplane/engine source noise as affected by differences between test and reference airspeeds. In addition to the effect on duration, the effects of airspeed on component noise sources must be accounted for as follows: for conventional airplane configurations, when differences between test and reference airspeeds exceed 15 knots (28 km/h) true airspeed, test data and/or analysis approved by the FAA must be used to quantify the effects of the airspeed adjustment on resulting certification noise levels.

A36.9.1.2 The “integrated” method of adjustment, described in section A36.9.4, must be used on takeoff or approach under the following conditions:

- (a) When the amount of the adjustment (using the “simplified” method) is greater than 8 dB on flyover, or 4 dB on approach; or
- (b) When the resulting final EPNL value on flyover or approach (using the simplified method) is within 1 dB of the limiting noise levels as prescribed in section B36.5 of this part.

#### A36.9.2 *Flight profiles.*

As described below, flight profiles for both test and reference conditions are defined by their geometry relative to the ground, together with the associated airplane speed relative to the ground, and the associated engine control parameter(s) used for determining the noise emission of the airplane.

##### A36.9.2.1 *Takeoff Profile.*

Note: Figure A36–4 illustrates a typical takeoff profile.

- (a) The airplane begins the takeoff roll at point A, lifts off at point B and begins its first climb at a constant angle at point C. Where thrust or power (as appropriate) cut-back is used, it is started at point D and completed at point E. From here, the airplane begins a second climb at a constant angle up to point F, the end of the noise certification takeoff flight path.
- (b) Position  $K_1$  is the takeoff noise measuring station and  $AK_1$  is the distance from start of roll to the flyover measuring point. Position  $K_2$  is the lateral noise measuring station, which is located on a line parallel to, and the specified distance from, the runway center line where the noise level during takeoff is greatest.
- (c) The distance AF is the distance over which the airplane position is measured and synchronized with the noise measurements, as required by section A36.2.3.2 of this part.

##### A36.9.2.2 *Approach Profile.*

Note: Figure A36–5 illustrates a typical approach profile.

- (a) The airplane begins its noise certification approach flight path at point G and touches down on the runway at point J, at a distance OJ from the runway threshold.
- (b) Position  $K_3$  is the approach noise measuring station and  $K_3O$  is the distance from the approach noise measurement point to the runway threshold.
- (c) The distance GI is the distance over which the airplane position is measured and synchronized with the noise measurements, as required by section A36.2.3.2 of this part.

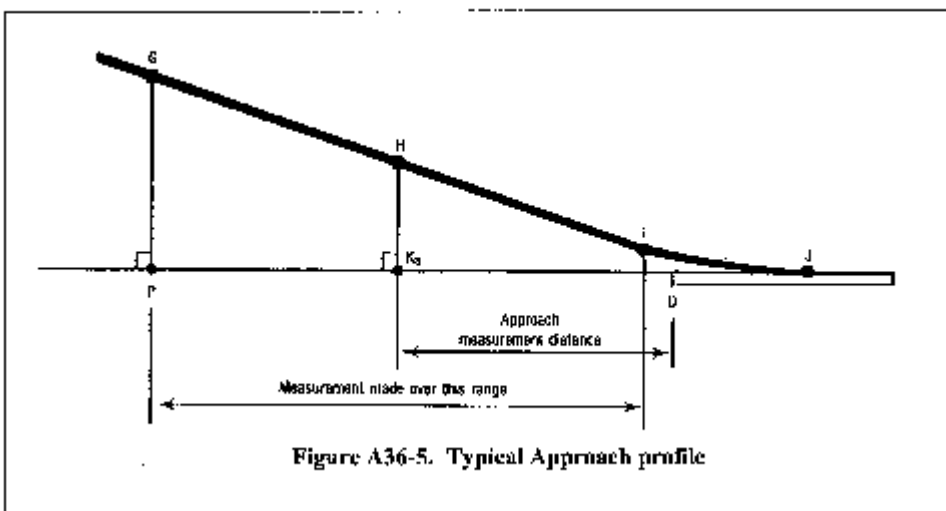
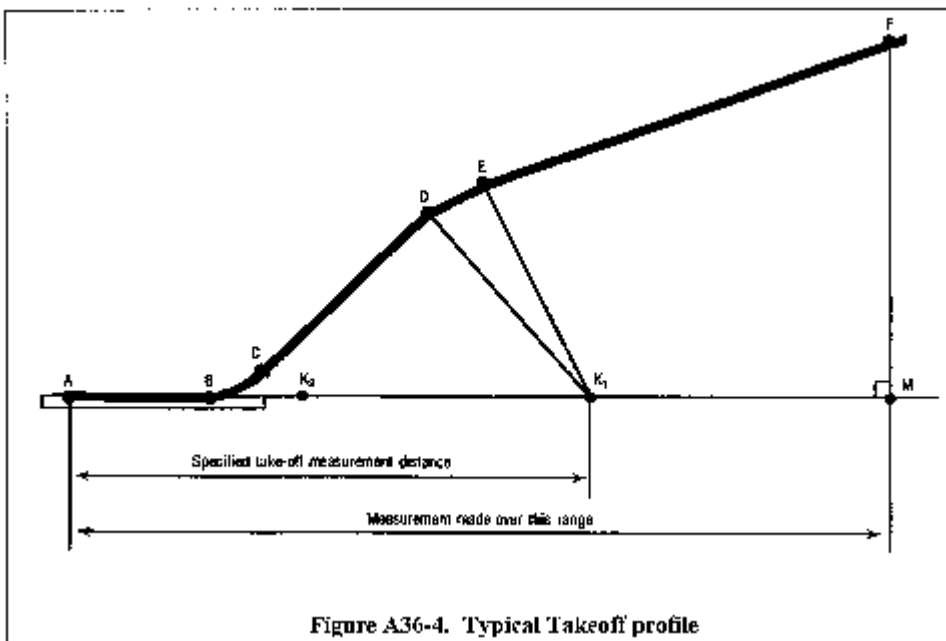

The airplane reference point for approach measurements is the instrument landing system (ILS) antenna. If no ILS antenna is installed an alternative reference point must be approved by the FAA.

*A36.9.3 Simplified method of adjustment.*

A36.9.3.1 *General.* As described below, the simplified adjustment method consists of applying adjustments (to the EPNL, which is calculated from the measured data) for the differences between measured and reference conditions at the moment of PNLTM.

A36.9.3.2 *Adjustments to PNL and PNLTM.*

(a) The portions of the test flight path and the reference flight path described below, and illustrated in Figure A36–6, include the noise time history that is relevant to the calculation of flyover and approach EPNL. In figure A36–6:

- (1) XY represents the portion of the measured flight path that includes the noise time history relevant to the calculation of flyover and approach EPNL;  $X_rY_r$  represents the corresponding portion of the reference flight path.
- (2) Q represents the airplane's position on the measured flight path at which the noise was emitted and observed as PNLTM at the noise measuring station K.  $Q_r$  is the corresponding position on the reference flight path, and  $K_r$  the reference measuring station. QK and  $Q_rK_r$  are, respectively, the measured

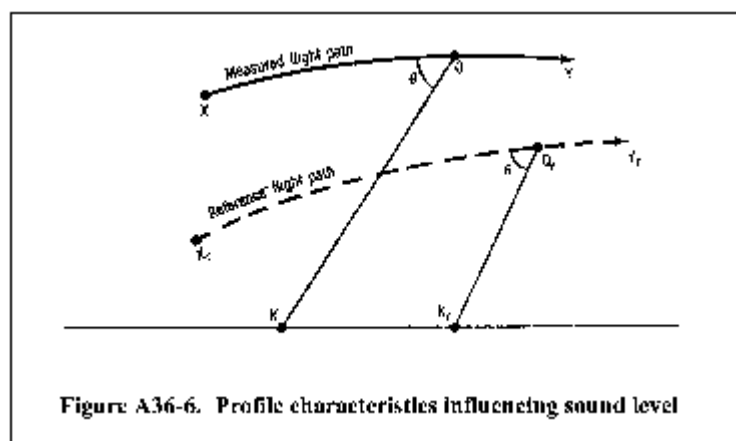

and reference noise propagation paths,  $Q_r$  being determined from the assumption that QK and  $Q_rK_r$  form the same angle  $\Theta$  with their respective flight paths.

(b) The portions of the test flight path and the reference flight path described in paragraph (b)(1) and (2), and illustrated in Figure A36–7(a) and (b), include the noise time history that is relevant to the calculation of lateral EPNL.

(1) In figure A36–7(a), XY represents the portion of the measured flight path that includes the noise time history that is relevant to the calculation of lateral EPNL; in figure A36–7(b),  $X_rY_r$  represents the corresponding portion of the reference flight path.

(2) Q represents the airplane position on the measured flight path at which the noise was emitted and observed as PNLTM at the noise measuring station K.  $Q_r$  is the corresponding position on the reference flight path, and  $K_r$  the reference measuring station. QK and  $Q_rK_r$  are, respectively, the measured and reference noise propagation paths. In this case  $K_r$  is only specified as being on a particular Lateral line;  $K_r$  and  $Q_r$  are therefore determined from the assumptions that QK and  $Q_rK_r$ :

(i) Form the same angle  $\Theta$  with their respective flight paths; and

(ii) Form the same angle  $\psi$  with the ground.

Note: For the lateral noise measurement, sound propagation is affected not only by inverse square and atmospheric attenuation, but also by ground absorption and reflection effects which depend mainly on the angle  $\psi$ .

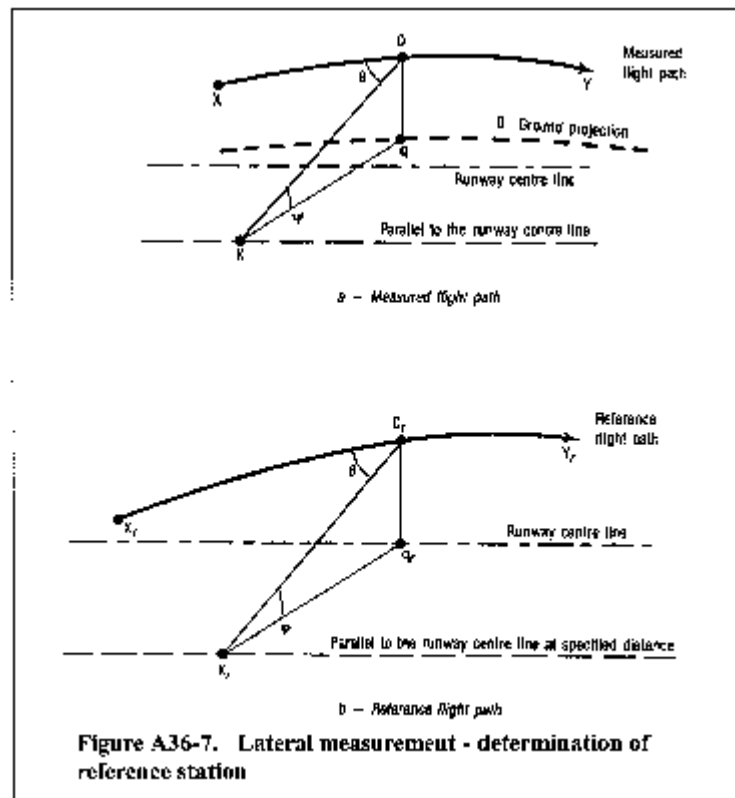

A36.9.3.2.1 The one-third octave band levels  $SPL(i)$  comprising PNL (the PNL at the moment of PNLTM observed at K) must be adjusted to reference levels  $SPL(i)_r$  as follows:

A36.9.3.2.1(a) For calculations using the English System of Units:

$$SPL(i)_r = SPL(i) + 0.001[\alpha(i) - \alpha(i)_0]QK$$

$$+ 0.001\alpha(i)_0(QK - Q_r K_r)$$

$$+ 20 \log(QK / Q_r K_r)$$

In this expression,

(1) The term  $0.001[\alpha(i) - \alpha(i)_0]QK$  is the adjustment for the effect of the change in sound attenuation coefficient, and  $\alpha(i)$  and  $\alpha(i)_0$  are the coefficients for the test and reference atmospheric conditions respectively, determined under section A36.7 of this appendix;

(2) The term  $0.001\alpha(i)_0(QK - Q_r K_r)$  is the adjustment for the effect of the change in the noise path

length on the sound attenuation;

(3) The term  $20 \log(QK/Q_rK_r)$  is the adjustment for the effect of the change in the noise path length due to the “inverse square” law;

(4)  $QK$  and  $Q_rK_r$  are measured in feet and  $\alpha(i)$  and  $\alpha(i)_0$  are expressed in dB/1000 ft.

A36.9.3.2.1(b) For calculations using the International System of Units:

$$SPL(i)_r = SPL(i) + 0.01[\alpha(i) - \alpha(i)_0]QK$$

$$+ 0.01\alpha(i)_0(QK - Q_rK_r)$$

$$+ 20 \log(QK/Q_rK_r)$$

In this expression,

(1) The term  $0.01[\alpha(i) - \alpha(i)_0]QK$  is the adjustment for the effect of the change in sound attenuation coefficient, and  $\alpha(i)$  and  $\alpha(i)_0$  are the coefficients for the test and reference atmospheric conditions respectively, determined under section A36.7 of this appendix;

(2) The term  $0.01\alpha(i)_0(QK - Q_rK_r)$  is the adjustment for the effect of the change in the noise path length on the sound attenuation;

(3) The term  $20 \log(QK/Q_rK_r)$  is the adjustment for the effect of the change in the noise path length due to the inverse square law;

(4)  $QK$  and  $Q_rK_r$  are measured in meters and  $\alpha(i)$  and  $\alpha(i)_0$  are expressed in dB/100 m.

A36.9.3.2.1.1 *PNLT Correction.*

(a) Convert the corrected values,  $SPL(i)_r$ , to  $PNLT_r$ ;

(b) Calculate the correction term  $\Delta_1$  using the following equation:

$$\Delta_1 = PNLTr - PNLTM$$

A36.9.3.2.1.2 Add  $\Delta_1$  arithmetically to the EPNL calculated from the measured data.

A36.9.3.2.2 If, during a test flight, several peak values of PNLT that are within 2 dB of PNLTM are observed, the procedure defined in section A36.9.3.2.1 must be applied at each peak, and the adjustment term, calculated according to section A36.9.3.2.1, must be added to each peak to give corresponding adjusted peak values of PNLT. If these peak values exceed the value at the moment of PNLTM, the maximum value of such exceedance must be added as a further adjustment to the EPNL calculated from the measured data.

A36.9.3.3 *Adjustments to duration correction.*

A36.9.3.3.1 Whenever the measured flight paths and/or the ground velocities of the test conditions

differ from the reference flight paths and/or the ground velocities of the reference conditions, duration adjustments must be applied to the EPNL values calculated from the measured data. The adjustments must be calculated as described below.

A36.9.3.3.2 For the flight path shown in Figure A36-6, the adjustment term is calculated as follows:

$$\Delta_2 = -7.5 \log(QK/Q_r K_r) + 10 \log(V/V_r)$$

(a) Add  $\Delta_2$  arithmetically to the EPNL calculated from the measured data.

#### A36.9.3.4 *Source noise adjustments.*

A36.9.3.4.1 To account for differences between the parameters affecting engine noise as measured in the certification flight tests, and those calculated or specified in the reference conditions, the source noise adjustment must be calculated and applied. The adjustment is determined from the manufacturer's data approved by the FAA. Typical data used for this adjustment are illustrated in Figure A36-8 that shows a curve of EPNL versus the engine control parameter  $\mu$ , with the EPNL data being corrected to all the other relevant reference conditions (airplane mass, speed and altitude, air temperature) and for the difference in noise between the test engine and the average engine (as defined in section B36.7(b)(7)). A sufficient number of data points over a range of values of  $\mu_r$  is required to calculate the source noise adjustments for lateral, flyover and approach noise measurements.

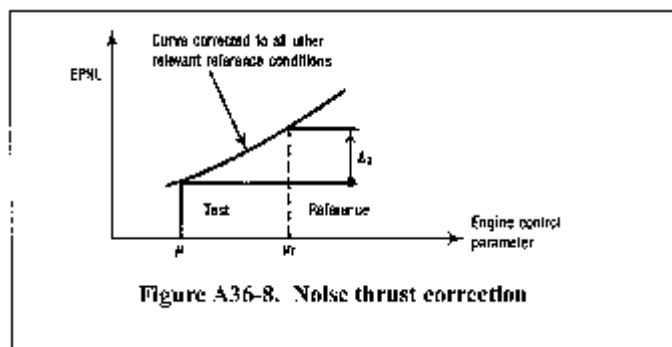

[View or download PDF](#)

A36.9.3.4.2 Calculate adjustment term  $\Delta_3$  by subtracting the EPNL value corresponding to the parameter  $\mu$  from the EPNL value corresponding to the parameter  $\mu_r$ . Add  $\Delta_3$  arithmetically to the EPNL value calculated from the measured data.

#### A36.9.3.5 *Symmetry adjustments.*

A36.9.3.5.1 A symmetry adjustment to each lateral noise value (determined at the section B36.4(b) measurement points), is to be made as follows:

(a) If the symmetrical measurement point is opposite the point where the highest noise level is obtained on the main lateral measurement line, the certification noise level is the arithmetic mean of the noise levels measured at these two points (see Figure A36-9(a));



(b) If the condition described in paragraph (a) of this section is not met, then it is assumed that the variation of noise with the altitude of the airplane is the same on both sides; there is a constant difference between the lines of noise versus altitude on both sides (see figure A36-9(b)). The certification noise level is the maximum value of the mean between these lines.

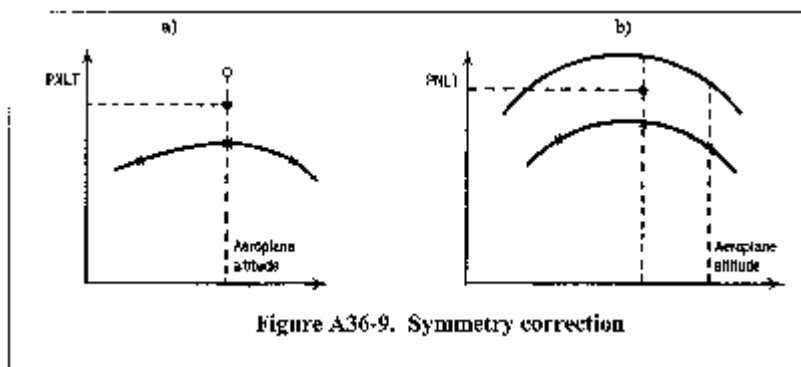

[View or download PDF](#)

**A36.9.4 Integrated method of adjustment**

**A36.9.4.1 General.** As described in this section, the integrated adjustment method consists of recomputing under reference conditions points on the PNL time history corresponding to measured points obtained during the tests, and computing EPNL directly for the new time history obtained in this way. The main principles are described in sections A36.9.4.2 through A36.9.4.4.1.

**A36.9.4.2 PNL computations.**

(a) The portions of the test flight path and the reference flight path described in paragraph (a)(1) and (2), and illustrated in Figure A36-10, include the noise time history that is relevant to the calculation of flyover and approach EPNL. In figure A36-10:

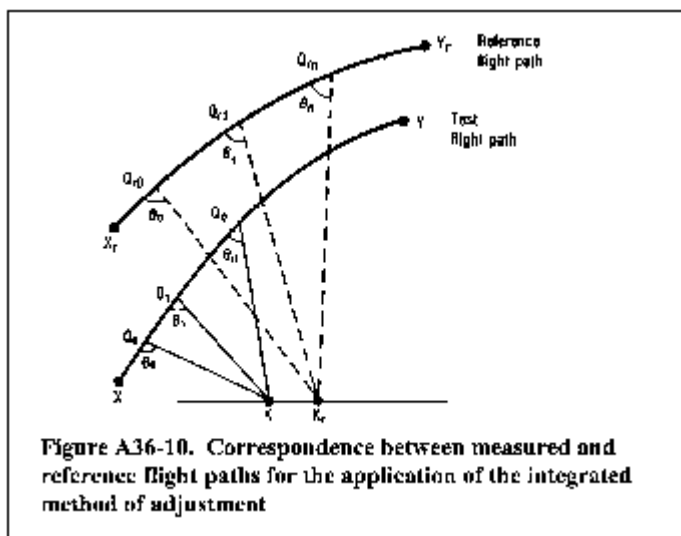

[View or download PDF](#)

- (1) XY represents the portion of the measured flight path that includes the noise time history relevant to the calculation of flyover and approach EPNL;  $X_r Y_r$  represents the corresponding reference flight path.
  - (2) The points  $Q_0$ ,  $Q_1$ ,  $Q_n$  represent airplane positions on the measured flight path at time  $t_0$ ,  $t_1$  and  $t_n$  respectively. Point  $Q_1$  is the point at which the noise was emitted and observed as one-third octave values  $SPL(i)_1$  at the noise measuring station K at time  $t_1$ . Point  $Q_{r1}$  represents the corresponding position on the reference flight path for noise observed as  $SPL(i)_{r1}$  at the reference measuring station  $K_r$  at time  $t_{r1}$ .  $Q_1 K$  and  $Q_{r1} K_r$  are respectively the measured and reference noise propagation paths, which in each case form the angle  $\Theta_1$  with their respective flight paths.  $Q_{r0}$  and  $Q_{rn}$  are similarly the points on the reference flight path corresponding to  $Q_0$  and  $Q_n$  on the measured flight path.  $Q_0$  and  $Q_n$  are chosen so that between  $Q_{r0}$  and  $Q_{rn}$  all values of  $PNLT_r$  (computed as described in paragraphs A36.9.4.2.2 and A36.9.4.2.3) within 10 dB of the peak value are included.
- (b) The portions of the test flight path and the reference flight path described in paragraph (b)(1) and (2), and illustrated in *Figure A36-11(a) and (b)*, include the noise time history that is relevant to the calculation of lateral EPNL.
- (1) In figure A36-11(a) XY represents the portion of the measured flight path that includes the noise time history that is relevant to the calculation of lateral EPNL; in figure A36-11(b),  $X_r Y_r$  represents the corresponding portion of the reference flight path.
  - (2) The points  $Q_0$ ,  $Q_1$  and  $Q_n$  represent airplane positions on the measured flight path at time  $t_0$ ,  $t_1$  and  $t_n$  respectively. Point  $Q_1$  is the point at which the noise was emitted and observed as one-third octave values  $SPL(i)_1$  at the noise measuring station K at time  $t_1$ . The point  $Q_{r1}$  represents the corresponding position on the reference flight path for noise observed as  $SPL(i)_{r1}$  at the measuring station  $K_r$  at time  $t_{r1}$ .  $Q_1 K$  and  $Q_{r1} K_r$  are respectively the measured and reference noise propagation paths.  $Q_{r0}$  and  $Q_{rn}$  are similarly the points on the reference flight path corresponding to  $Q_0$  and  $Q_n$  on the measured flight path.

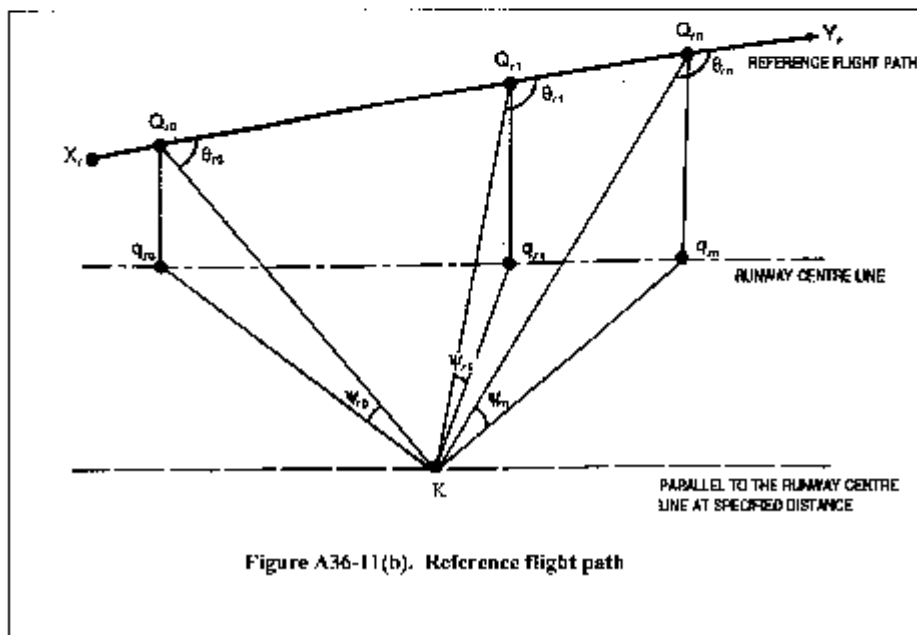
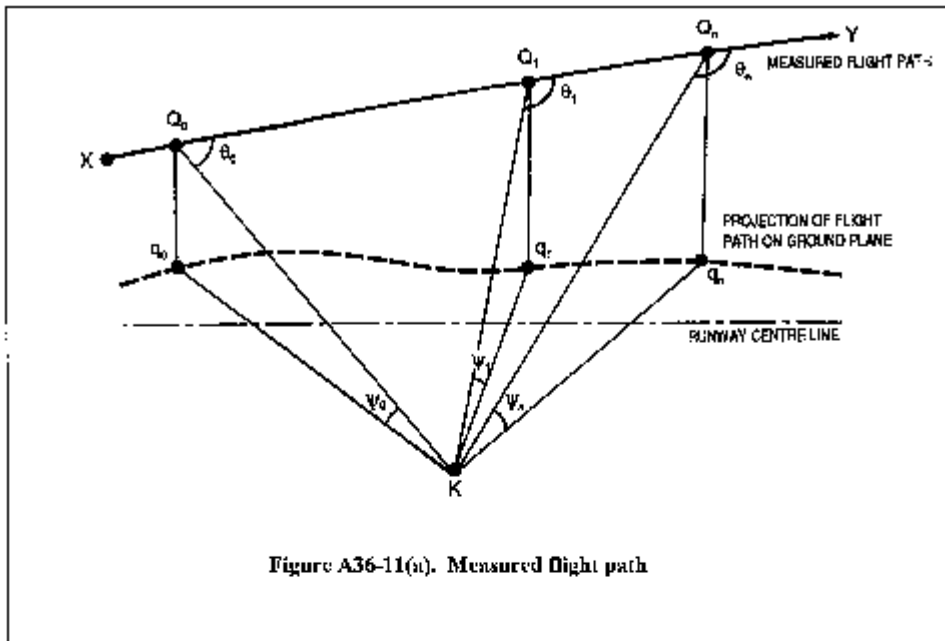

[View or download PDF](#)

$Q_0$  and  $Q_n$  are chosen so that between  $Q_{r0}$  and  $Q_{rn}$  all values of  $PNLT_r$  (computed as described in paragraphs A36.9.4.2.2 and A36.9.4.2.3) within 10 dB of the peak value are included. In this case  $K_r$  is only specified as being on a particular lateral line. The position of  $K_r$  and  $Q_{r1}$  are determined from the following requirements.

- (i)  $Q_1K$  and  $Q_{r1}K_r$  form the same angle  $\Theta_1$  with their respective flight paths; and
- (ii) The differences between the angles  $\theta_1$  and  $\theta_{r1}$  must be minimized using a method, approved by the FAA. The differences between the angles are minimized since, for geometrical reasons, it is generally not possible to choose  $K_r$  so that the condition described in paragraph

A36.9.4.2(b)(2)(i) is met while at the same time keeping  $r_1$  and  $r_1$  equal.

Note: For the lateral noise measurement, sound propagation is affected not only by “inverse square” and atmospheric attenuation, but also by ground absorption and reflection effects which depend mainly on the angle.

A36.9.4.2.1 In paragraphs A36.9.4.2(a)(2) and (b)(2) the time  $t_{r1}$  is later (for  $Q_{r1}K_r > Q_1K$ ) than  $t_1$  by two separate amounts:

- (1) The time taken for the airplane to travel the distance  $Q_{r1}Q_{r0}$  at a speed  $V_r$  less the time taken for it to travel  $Q_1Q_0$  at  $V$ ;
- (2) The time taken for sound to travel the distance  $Q_{r1}K_r - Q_1K$ .

Note: For the flight paths described in paragraphs A36.9.4.2(a) and (b), the use of thrust or power cut-back will result in test and reference flight paths at full thrust or power and at cut-back thrust or power. Where the transient region between these thrust or power levels affects the final result, an interpolation must be made between them by an approved method such as that given in the current advisory circular for this part.

A36.9.4.2.2 The measured values of  $SPL(i)_1$  must be adjusted to the reference values  $SPL(i)_r$  to account for the differences between measured and reference noise path lengths and between measured and reference atmospheric conditions, using the methods of section A36.9.3.2.1 of this appendix. A corresponding value of  $PNL_{r1}$  must be computed according to the method in section A36.4.2. Values of  $PNL_r$  must be computed for times  $t_0$  through  $t_n$ .

A36.9.4.2.3 For each value of  $PNL_{r1}$ , a tone correction factor  $C_1$  must be determined by analyzing the reference values  $SPL(i)_r$  using the methods of section A36.4.3 of this appendix, and added to  $PNL_{r1}$  to yield  $PNLT_{r1}$ . Using the process described in this paragraph, values of  $PNLT_r$  must be computed for times  $t_0$  through  $t_n$ .

**A36.9.4.3 Duration correction.**

A36.9.4.3.1 The values of  $PNLT_r$  corresponding to those of  $PNLT$  at each one-half second interval must be plotted against time ( $PNLT_{r1}$  at time  $t_{r1}$ ). The duration correction must then be determined using the method of section A36.4.5.1 of this appendix, to yield  $EPNL_r$ .

**A36.9.4.4 Source Noise Adjustment.**

A36.9.4.4.1 A source noise adjustment,  $\Delta_3$ , must be determined using the methods of section A36.9.3.4 of this appendix.

**A36.9.5 Flight Path Identification Positions**

Position	Description
A	Start of Takeoff roll.
B	Lift-off.

C	Start of first constant climb.
D	Start of thrust reduction.
E	Start of second constant climb.
F	End of noise certification Takeoff flight path.
G	Start of noise certification Approach flight path.
H	Position on Approach path directly above noise measuring station.
I	Start of level-off.
J	Touchdown.
K	Noise measurement point.
K <sub>r</sub>	Reference measurement point.
K <sub>1</sub>	Flyover noise measurement point.
K <sub>2</sub>	Lateral noise measurement point.
K <sub>3</sub>	Approach noise measurement point.
M	End of noise certification Takeoff flight track.
O	Threshold of Approach end of runway.
P	Start of noise certification Approach flight track.
Q	Position on measured Takeoff flight path corresponding to apparent PNLTM at station K See section A36.9.3.2.
Q <sub>r</sub>	Position on corrected Takeoff flight path corresponding to PNLTM at station K. See section A36.9.3.2.
V	Airplane test speed.
V <sub>r</sub>	Airplane reference speed.

### A36.9.6 Flight Path Distances

Distance	Unit	Meaning
AB	Feet (meters)	Length of takeoff roll. The distance along the runway between the start of takeoff roll and lift off.
AK	Feet (meters)	Takeoff measurement distance. The distance from the start of roll to the takeoff noise measurement station along the extended center line of the runway.
AM	Feet (meters)	Takeoff flight track distance. The distance from the start of roll to the takeoff flight track position along the extended center line of the runway after which the position of the airplane need no longer be recorded.

QK	Feet (meters)	Measured noise path. The distance from the measured airplane position Q to station K.
Q <sub>r</sub> K <sub>r</sub>	Feet (meters)	Reference noise path. The distance from the reference airplane position Q <sub>r</sub> to station K <sub>r</sub> .
K <sub>3</sub> H	Feet (meters)	Airplane approach height. The height of the airplane above the approach measuring station.
OK <sub>3</sub>	Feet (meters)	Approach measurement distance. The distance from the runway threshold to the approach measurement station along the extended center line of the runway.
OP	Feet (meters)	Approach flight track distance. The distance from the runway threshold to the approach flight track position along the extended center line of the runway after which the position of the airplane need no longer be recorded.

[Amdt. 36–54, 67 FR 45212, July 8, 2002; Amdt. 36–24, 67 FR 63195, 63196, Oct. 10, 2002; 68 FR 1512, Jan 10, 2003; Amdt. 36–26, 70 FR 38749, July 5, 2005]

## **Appendix B to Part 36—Noise Levels for Transport Category and Jet Airplanes Under §36.103**

Sec.

B36.1 *Noise Measurement and Evaluation.*

B36.2 *Noise Evaluation Metric.*

B36.3 *Reference Noise Measurement Points.*

B36.4 *Test Noise Measurement Points.*

B36.5 *Maximum Noise Levels.*

B36.6 *Trade-Offs.*

B36.7 *Noise Certification Reference Procedures and Conditions.*

B36.8 *Noise Certification Test Procedures.*

### *Section B36.1 Noise measurement and evaluation*

(a) The procedures of Appendix A of this part, or approved equivalent procedures, must be used to determine noise levels of an airplane. These noise levels must be used to show compliance with the requirements of this appendix.

(b) For Stage 4 airplanes, an acceptable alternative for noise measurement and evaluation is Appendix 2 to the International Civil Aviation Organization (ICAO) Annex 16,

Environmental Protection, Volume I, Aircraft Noise, Third Edition, July 1993, Amendment 7, effective March 21, 2002. [Incorporated by reference, see §36.6].

#### *Section B36.2 Noise Evaluation Metric*

The noise evaluation metric is the effective perceived noise level expressed in EPNdB, as calculated using the procedures of appendix A of this part.

#### *Section B36.3 Reference Noise Measurement Points*

When tested using the procedures of this part, except as provided in section B36.6, an airplane may not exceed the noise levels specified in section B36.5 at the following points on level terrain:

(a) Lateral full-power reference noise measurement point:

(1) For jet airplanes: The point on a line parallel to and 1,476 feet (450 m) from the runway centerline, or extended centerline, where the noise level after lift-off is at a maximum during takeoff. For the purpose of showing compliance with Stage 1 or Stage 2 noise limits for an airplane powered by more than three jet engines, the distance from the runway centerline must be 0.35 nautical miles (648 m). For jet airplanes, when approved by the FAA, the maximum lateral noise at takeoff thrust may be assumed to occur at the point (or its approved equivalent) along the extended centerline of the runway where the airplane reaches 985 feet (300 meters) altitude above ground level. A height of 1427 feet (435 meters) may be assumed for Stage 1 or Stage 2 four engine airplanes. The altitude of the airplane as it passes the noise measurement points must be within +328 to -164 feet (+100 to -50 meters) of the target altitude. For airplanes powered by other than jet engines, the altitude for maximum lateral noise must be determined experimentally.

(2) For propeller-driven airplanes: The point on the extended centerline of the runway above which the airplane, at full takeoff power, reaches a height of 2,133 feet (650 meters). For tests conducted before August 7, 2002, an applicant may use the measurement point specified in section B36.3(a)(1) as an alternative.

(b) Flyover reference noise measurement point: The point on the extended centerline of the runway that is 21,325 feet (6,500 m) from the start of the takeoff roll;

(c) Approach reference noise measurement point: The point on the extended centerline of the runway that is 6,562 feet (2,000 m) from the runway threshold. On level ground, this corresponds to a position that is 394 feet (120 m) vertically below the 3° descent path, which originates at a point on the runway 984 feet (300 m) beyond the threshold.

#### *Section B36.4 Test noise measurement points.*

(a) If the test noise measurement points are not located at the reference noise measurement points, any corrections for the difference in position are to be made using the same adjustment procedures as for the differences between test and reference flight paths.

(b) The applicant must use a sufficient number of lateral test noise measurement points to

demonstrate to the FAA that the maximum noise level on the appropriate lateral line has been determined. For jet airplanes, simultaneous measurements must be made at one test noise measurement point at its symmetrical point on the other side of the runway. Propeller-driven airplanes have an inherent asymmetry in lateral noise. Therefore, simultaneous measurements must be made at each and every test noise measurement point at its symmetrical position on the opposite side of the runway. The measurement points are considered to be symmetrical if they are longitudinally within 33 feet ( $\pm 10$  meters) of each other.

#### *Section B36.5 Maximum Noise Levels*

Except as provided in section B36.6 of this appendix, maximum noise levels, when determined in accordance with the noise evaluation methods of appendix A of this part, may not exceed the following:

- (a) For acoustical changes to Stage 1 airplanes, regardless of the number of engines, the noise levels prescribed under §36.7(c) of this part.
- (b) For any Stage 2 airplane regardless of the number of engines:
  - (1) Flyover: 108 EPNdB for maximum weight of 600,000 pounds or more; for each halving of maximum weight (from 600,000 pounds), reduce the limit by 5 EPNdB; the limit is 93 EPNdB for a maximum weight of 75,000 pounds or less.
  - (2) Lateral and approach: 108 EPNdB for maximum weight of 600,000 pounds or more; for each halving of maximum weight (from 600,000 pounds), reduce the limit by 2 EPNdB; the limit is 102 EPNdB for a maximum weight of 75,000 pounds or less.
- (c) For any Stage 3 airplane:
  - (1) Flyover.
    - (i) For airplanes with more than 3 engines: 106 EPNdB for maximum weight of 850,000 pounds or more; for each halving of maximum weight (from 850,000 pounds), reduce the limit by 4 EPNdB; the limit is 89 EPNdB for a maximum weight of 44,673 pounds or less;
    - (ii) For airplanes with 3 engines: 104 EPNdB for maximum weight of 850,000 pounds or more; for each halving of maximum weight (from 850,000 pounds), reduce the limit by 4 EPNdB; the limit is 89 EPNdB for a maximum weight of 63,177 pounds or less; and
    - (iii) For airplanes with fewer than 3 engines: 101 EPNdB for maximum weight of 850,000 pounds or more; for each halving of maximum weight (from 850,000 pounds), reduce the limit by 4 EPNdB; the limit is 89 EPNdB for a maximum weight of 106,250 pounds or less.
  - (2) Lateral, regardless of the number of engines: 103 EPNdB for maximum weight of 882,000 pounds or more; for each halving of maximum weight (from 882,000 pounds), reduce the limit by 2.56 EPNdB; the limit is 94 EPNdB for a maximum weight of 77,200 pounds or less.



- (3) Approach, regardless of the number of engines: 105 EPNdB for maximum weight of 617,300 pounds or more; for each halving of maximum weight (from 617,300 pounds), reduce the limit by 2.33 EPNdB; the limit is 98 EPNdB for a maximum weight of 77,200 pounds or less.
- (d) For any Stage 4 airplane, the flyover, lateral, and approach maximum noise levels are prescribed in Chapter 4, Paragraph 4.4, Maximum Noise Levels, and Chapter 3, Paragraph 3.4, Maximum Noise Levels, of the International Civil Aviation Organization (ICAO) Annex 16, Environmental Protection, Volume I, Aircraft Noise, Third Edition, July 1993, Amendment 7, effective March 21, 2002. [Incorporated by reference, see §36.6].

#### *Section B36.6 Trade-Offs*

Except when prohibited by sections 36.7(c)(1) and 36.7(d)(1)(ii), if the maximum noise levels are exceeded at any one or two measurement points, the following conditions must be met:

- (a) The sum of the exceedance(s) may not be greater than 3 EPNdB;
- (b) Any exceedance at any single point may not be greater than 2 EPNdB, and
- (c) Any exceedance(s) must be offset by a corresponding amount at another point or points.

#### *Section B36.7 Noise Certification Reference Procedures and Conditions*

(a) General conditions:

- (1) All reference procedures must meet the requirements of section 36.3 of this part.
- (2) Calculations of airplane performance and flight path must be made using the reference procedures and must be approved by the FAA.
- (3) Applicants must use the takeoff and approach reference procedures prescribed in paragraphs (b) and (c) of this section.
- (4) [Reserved]
- (5) The reference procedures must be determined for the following reference conditions. The reference atmosphere is homogeneous in terms of temperature and relative humidity when used for the calculation of atmospheric absorption coefficients.
- (i) Sea level atmospheric pressure of 2116 pounds per square foot (psf) (1013.25 hPa);
- (ii) Ambient sea-level air temperature of 77 °F (25 °C, i.e. ISA+10 °C);
- (iii) Relative humidity of 70 per cent;
- (iv) Zero wind.
- (v) In defining the reference takeoff flight path(s) for the takeoff and lateral noise measurements,

the runway gradient is zero.

(b) Takeoff reference procedure:

The takeoff reference flight path is to be calculated using the following:

(1) Average engine takeoff thrust or power must be used from the start of takeoff to the point where at least the following height above runway level is reached. The takeoff thrust/power used must be the maximum available for normal operations given in the performance section of the airplane flight manual under the reference atmospheric conditions given in section B36.7(a)(5).

(i) For Stage 1 airplanes and for Stage 2 airplanes that do not have jet engines with a bypass ratio of 2 or more, the following apply:

(A): For airplanes with more than three jet engines—700 feet (214 meters).

(B): For all other airplanes—1,000 feet (305 meters).

(ii) For Stage 2 airplanes that have jet engines with a bypass ratio of 2 or more and for Stage 3 airplanes, the following apply:

(A): For airplanes with more than three engines—689 feet (210 meters).

(B): For airplanes with three engines—853 feet (260 meters).

(C): For airplanes with fewer than three engines—984 feet (300 meters).

(2) Upon reaching the height specified in paragraph (b)(1) of this section, airplane thrust or power must not be reduced below that required to maintain either of the following, whichever is greater:

(i) A climb gradient of 4 per cent; or

(ii) In the case of multi-engine airplanes, level flight with one engine inoperative.

(3) For the purpose of determining the lateral noise level, the reference flight path must be calculated using full takeoff power throughout the test run without a reduction in thrust or power. For tests conducted before August 7, 2002, a single reference flight path that includes thrust cutback in accordance with paragraph (b)(2) of this section, is an acceptable alternative in determining the lateral noise level.

(4) The takeoff reference speed is the all-engine operating takeoff climb speed selected by the applicant for use in normal operation; this speed must be at least  $V_2+10kt$  ( $V_2+19km/h$ ) but may not be greater than  $V_2+20kt$  ( $V_2+37km/h$ ). This speed must be attained as soon as practicable after lift-off and be maintained throughout the takeoff noise certification test. For Concorde airplanes, the test day speeds and the acoustic day reference speed are the minimum approved value of  $V_2+35$  knots, or the all-engines-operating speed at 35 feet, whichever speed is greater as determined under the regulations constituting the type

certification basis of the airplane; this reference speed may not exceed 250 knots. For all airplanes, noise values measured at the test day speeds must be corrected to the acoustic day reference speed.

- (5) The takeoff configuration selected by the applicant must be maintained constantly throughout the takeoff reference procedure, except that the landing gear may be retracted. Configuration means the center of gravity position, and the status of the airplane systems that can affect airplane performance or noise. Examples include, the position of lift augmentation devices, whether the APU is operating, and whether air bleeds and engine power take-offs are operating;
- (6) The weight of the airplane at the brake release must be the maximum takeoff weight at which the noise certification is requested, which may result in an operating limitation as specified in §36.1581(d); and
- (7) The average engine is defined as the average of all the certification compliant engines used during the airplane flight tests, up to and during certification, when operating within the limitations and according to the procedures given in the Flight Manual. This will determine the relationship of thrust/power to control parameters (e.g.,  $N_1$  or EPR). Noise measurements made during certification tests must be corrected using this relationship.

(c) Approach reference procedure:

The approach reference flight path must be calculated using the following:

- (1) The airplane is stabilized and following a 3° glide path;
- (2) For subsonic airplanes, a steady approach speed of  $V_{ref} + 10$  kts ( $V_{ref} + 19$  km/h) with thrust and power stabilized must be established and maintained over the approach measuring point.  $V_{ref}$  is the reference landing speed, which is defined as the speed of the airplane, in a specified landing configuration, at the point where it descends through the landing screen height in the determination of the landing distance for manual landings. For Concorde airplanes, a steady approach speed that is either the landing reference speed + 10 knots or the speed used in establishing the approved landing distance under the airworthiness regulations constituting the type certification basis of the airplane, whichever speed is greater. This speed must be established and maintained over the approach measuring point.
- (3) The constant approach configuration used in the airworthiness certification tests, but with the landing gear down, must be maintained throughout the approach reference procedure;
- (4) The weight of the airplane at touchdown must be the maximum landing weight permitted in the approach configuration defined in paragraph (c)(3) of this section at which noise certification is requested, except as provided in §36.1581(d) of this part; and
- (5) The most critical configuration must be used; this configuration is defined as that which produces the highest noise level with normal deployment of aerodynamic control surfaces including lift and drag producing devices, at the weight at which certification is requested. This configuration includes all those items listed in section A36.5.2.5 of appendix A of this part that contribute to the noisiest continuous state at the maximum landing weight in

normal operation.

### *Section B36.8 Noise Certification Test Procedures*

- (a) All test procedures must be approved by the FAA.
- (b) The test procedures and noise measurements must be conducted and processed in an approved manner to yield the noise evaluation metric EPNL, in units of EPNdB, as described in appendix A of this part.
- (c) Acoustic data must be adjusted to the reference conditions specified in this appendix using the methods described in appendix A of this part. Adjustments for speed and thrust must be made as described in section A36.9 of this part.
- (d) If the airplane's weight during the test is different from the weight at which noise certification is requested, the required EPNL adjustment may not exceed 2 EPNdB for each takeoff and 1 EPNdB for each approach. Data approved by the FAA must be used to determine the variation of EPNL with weight for both takeoff and approach test conditions. The necessary EPNL adjustment for variations in approach flight path from the reference flight path must not exceed 2 EPNdB.
- (e) For approach, a steady glide path angle of  $3^{\circ} \pm 0.5^{\circ}$  is acceptable.
- (f) If equivalent test procedures different from the reference procedures are used, the test procedures and all methods for adjusting the results to the reference procedures must be approved by the FAA. The adjustments may not exceed 16 EPNdB on takeoff and 8 EPNdB on approach. If the adjustment is more than 8 EPNdB on takeoff, or more than 4 EPNdB on approach, the resulting numbers must be more than 2 EPNdB below the limit noise levels specified in section B36.5.
- (g) During takeoff, lateral, and approach tests, the airplane variation in instantaneous indicated airspeed must be maintained within  $\pm 3\%$  of the average airspeed between the 10 dB-down points. This airspeed is determined by the pilot's airspeed indicator. However, if the instantaneous indicated airspeed exceeds  $\pm 3$  kt ( $\pm 5.5$  km/h) of the average airspeed over the 10 dB-down points, and is determined by the FAA representative on the flight deck to be due to atmospheric turbulence, then the flight so affected must be rejected for noise certification purposes.

Note: Guidance material on the use of equivalent procedures is provided in the current advisory circular for this part.

[Amdt. 36–54, 67 FR 45235, July 8, 2002; Amdt. 36–24, 67 FR 63196, Oct. 10, 2002; 68 FR 1512, Jan. 10, 2003; Amdt. 36–26, 70 FR 38749, July 5, 2005]

### **Appendixes C–E to Part 36 [Reserved]**

### **Appendix F to Part 36—Flyover Noise Requirements for Propeller-Driven Small Airplane and Propeller-Driven, Commuter Category Airplane Certification Tests Prior to December 22, 1988**

part a—general

Sec.

F36.1 *Scope.*

part b—noise measurement

F36.101 *General test conditions.*

F36.103 *Acoustical measurement system.*

F36.105 *Sensing, recording, and reproducing equipment.*

F36.107 *Noise measurement procedures.*

F36.109 *Data recording, reporting, and approval.*

F36.111 *Flight procedures.*

part c—data correction

F36.201 *Correction of data.*

F36.203 *Validity of results.*

part d—noise limits

F36.301 *Aircraft noise limits.*

part a—general

*Section F36.1 Scope.* This appendix prescribes noise level limits and procedures for measuring and correcting noise data for the propeller driven small airplanes specified in §§36.1 and 36.501(b).

part b—noise measurement

*Sec. F36.101 General test conditions.*

(a) The test area must be relatively flat terrain having no excessive sound absorption characteristics such as those caused by thick, matted, or tall grass, by shrubs, or by wooded areas. No obstructions which significantly influence the sound field from the airplane may exist within a conical space above the measurement position, the cone being defined by an axis normal to the ground and by a half-angle 75 degrees from this axis.

(b) The tests must be carried out under the following conditions:

(1) There may be no precipitation.

- (2) Relative humidity may not be higher than 90 percent or lower than 30 percent.
- (3) Ambient temperature may not be above 86 degrees F. or below 41 degrees F. at 33' above ground. If the measurement site is within 1 n.m. of an airport thermometer the airport reported temperature may be used.
- (4) Reported wind may not be above 10 knots at 33' above ground. If wind velocities of more than 4 knots are reported, the flight direction must be aligned to within  $\pm 15$  degrees of wind direction and flights with tail wind and head wind must be made in equal numbers. If the measurement site is within 1 n.m. of an airport anemometer, the airport reported wind may be used.
- (5) There may be no temperature inversion or anomalous wind conditions that would significantly alter the noise level of the airplane when the noise is recorded at the required measuring point.
- (6) The flight test procedures, measuring equipment, and noise measurement procedures must be approved by the FAA.
- (7) Sound pressure level data for noise evaluation purposes must be obtained with acoustical equipment that complies with section F36.103 of this appendix.

*Sec. F36.103 Acoustical measurement system.* The acoustical measurement system must consist of approved equipment equivalent to the following:

- (a) A microphone system with frequency response compatible with measurement and analysis system accuracy as prescribed in section F36.105 of this appendix.
- (b) Tripods or similar microphone mountings that minimize interference with the sound being measured.
- (c) Recording and reproducing equipment characteristics, frequency response, and dynamic range compatible with the response and accuracy requirements of section F36.105 of this appendix.
- (d) Acoustic calibrators using sine wave or broadband noise of known sound pressure level. If broadband noise is used, the signal must be described in terms of its average and maximum root-mean-square (rms) value for nonoverload signal level.

*Sec. F36.105 Sensing, recording, and reproducing equipment.*

- (a) The noise produced by the airplane must be recorded. A magnetic tape recorder is acceptable.
- (b) The characteristics of the system must comply with the recommendations in International Electrotechnical Commission (IEC) Publication No. 179, entitled "Precision Sound Level Meters" as incorporated by reference in Part 36 under §36.6 of this part.
- (c) The response of the complete system to a sensibly plane progressive sinusoidal wave of constant amplitude must lie within the tolerance limits specified in IEC Publication No. 179, dated

1973, over the frequency range 45 to 11,200 Hz.

- (d) If limitations of the dynamic range of the equipment make it necessary, high frequency pre-emphasis must be added to the recording channel with the converse de-emphasis on playback. The pre-emphasis must be applied such that the instantaneous recorded sound pressure level of the noise signal between 800 and 11,200 Hz does not vary more than 20 dB between the maximum and minimum one-third octave bands.
- (e) If requested by the Administrator, the recorded noise signal must be read through an “A” filter with dynamic characteristics designated “slow,” as defined in IEC Publication No. 179, dated 1973. The output signal from the filter must be fed to a rectifying circuit with square law rectification, integrated with time constants for charge and discharge of about 1 second or 800 milliseconds.
- (f) The equipment must be acoustically calibrated using facilities for acoustic freefield calibration and if analysis of the tape recording is requested by the Administrator, the analysis equipment shall be electronically calibrated by a method approved by the FAA.
- (g) A windscreen must be employed with microphone during all measurements of aircraft noise when the wind speed is in excess of 6 knots.

*Sec. F36.107 Noise measurement procedures.*

- (a) The microphones must be oriented in a known direction so that the maximum sound received arrives as nearly as possible in the direction for which the microphones are calibrated. The microphone sensing elements must be approximately 4' above ground.
- (b) Immediately prior to and after each test; a recorded acoustic calibration of the system must be made in the field with an acoustic calibrator for the two purposes of checking system sensitivity and providing an acoustic reference level for the analysis of the sound level data.
- (c) The ambient noise, including both acoustical background and electrical noise of the measurement systems, must be recorded and determined in the test area with the system gain set at levels that will be used for aircraft noise measurements. If aircraft sound pressure levels do not exceed the background sound pressure levels by at least 10 dB(A), approved corrections for the contribution of background sound pressure level to the observed sound pressure level must be applied.

*Sec. F36.109 Data recording, reporting, and approval.*

- (a) Data representing physical measurements or corrections to measured data must be recorded in permanent form and appended to the record except that corrections to measurements for normal equipment response deviations need not be reported. All other corrections must be approved. Estimates must be made of the individual errors inherent in each of the operations employed in obtaining the final data.
- (b) Measured and corrected sound pressure levels obtained with equipment conforming to the specifications described in section F36.105 of this appendix must be reported.

- 
- (c) The type of equipment used for measurement and analysis of all acoustic, airplane performance, and meteorological data must be reported.
  - (d) The following atmospheric data, measured immediately before, after, or during each test at the observation points prescribed in section F36.101 of this appendix must be reported:
    - (1) Air temperature and relative humidity.
    - (2) Maximum, minimum, and average wind velocities.
  - (e) Comments on local topography, ground cover, and events that might interfere with sound recordings must be reported.
  - (f) The following airplane information must be reported:
    - (1) Type, model and serial numbers (if any) of airplanes, engines, and propellers.
    - (2) Any modifications or nonstandard equipment likely to affect the noise characteristics of the airplane.
    - (3) Maximum certificated takeoff weights.
    - (4) Airspeed in knots for each overflight of the measuring point.
    - (5) Engine performance in terms of revolutions per minute and other relevant parameters for each overflight.
    - (6) Aircraft height in feet determined by a calibrated altimeter in the aircraft, approved photographic techniques, or approved tracking facilities.
    - (g) Aircraft speed and position and engine performance parameters must be recorded at an approved sampling rate sufficient to ensure compliance with the test procedures and conditions of this appendix.

*Sec. F36.111 Flight procedures.*

- (a) Tests to demonstrate compliance with the noise level requirements of this appendix must include at least six level flights over the measuring station at a height of 1,000'  $\pm$ 30' and  $\pm$ 10 degrees from the zenith when passing overhead.
- (b) Each test over flight must be conducted:
  - (1) At not less than the highest power in the normal operating range provided in an Airplane Flight Manual, or in any combination of approved manual material, approved placard, or approved instrument markings; and
  - (2) At stabilized speed with propellers synchronized and with the airplane in cruise configuration, except that if the speed at the power setting prescribed in this paragraph would exceed the maximum speed authorized in level flight, accelerated flight is acceptable.



part c—data correction

*Sec. F36.201 Correction of data.*

- (a) Noise data obtained when the temperature is outside the range of 68 degrees F.  $\pm$ 9 degrees F., or the relative humidity is below 40 percent, must be corrected to 77 degrees F. and 70 percent relative humidity by a method approved by the FAA.
- (b) The performance correction prescribed in paragraph (c) of this section must be used. It must be determined by the method described in this appendix, and must be added algebraically to the measured value. It is limited to 5dB(A).
- (c) The performance correction must be computed by using the following formula:

$$\Delta dB = 60 - 20 \log_{10} \left\{ (11,430 - D_{50}) \frac{R/C}{V_y} + 50 \right\}$$

Where:

$D_{50}$ =Takeoff distance to 50 feet at maximum certificated takeoff weight.

R/C=Certificated best rate of climb (fpm).

$V_y$  =Speed for best rate of climb in the same units as rate of climb.

- (d) When takeoff distance to 50' is not listed as approved performance information, the figures of 2000 for single-engine airplanes and 1600' for multi-engine airplanes must be used.

*Sec. F36.203 Validity of results.*

- (a) The test results must produce an average dB(A) and its 90 percent confidence limits, the noise level being the arithmetic average of the corrected acoustical measurements for all valid test runs over the measuring point.
- (b) The samples must be large enough to establish statistically a 90 percent confidence limit not to exceed  $\pm 1.5$  dB(A). No test result may be omitted from the averaging process, unless omission is approved by the FAA.

part d—noise limits

*Sec. F36.301 Aircraft noise limits.*

- (a) Compliance with this section must be shown with noise data measured and corrected as prescribed in Parts B and C of this appendix.
- (b) For airplanes for which application for a type certificate is made on or after October 10, 1973, the noise level must not exceed 68 dB(A) up to and including aircraft weights of 1,320 pounds (600 kg.). For weights greater than 1,320 pounds up to and including 3,630 pounds

(1.650 kg.) the limit increases at the rate of 1 dB/165 pounds (1 dB/75 kg.) to 82 dB(A) at 3,630 pounds, after which it is constant at 82 dB(A). However, airplanes produced under type certificates covered by this paragraph must also meet paragraph (d) of this section for the original issuance of standard airworthiness certificates or restricted category airworthiness certificates if those airplanes have not had flight time before the date specified in that paragraph.

(c) For airplanes for which application for a type certificate is made on or after January 1, 1975, the noise levels may not exceed the noise limit curve prescribed in paragraph (b) of this section, except that 80 dB(A) may not be exceeded.

(d) For airplanes for which application is made for a standard airworthiness certificate or for a restricted category airworthiness certificate, and that have not had any flight time before January 1, 1980, the requirements of paragraph (c) of this section apply, regardless of date of application, to the original issuance of the certificate for that airplane.

[Doc. No. 13243, 40 FR 1035, Jan. 6, 1975; 40 FR 6347, Feb. 11, 1975, as amended by Amdt. 36-6, 41 FR 56064, Dec. 23, 1976; Amdt. 36-6, 42 FR 4113, Jan. 24, 1977; Amdt. 36-9, 43 FR 8754, Mar. 2, 1978; Amdt. 36-13, 52 FR 1836, Jan. 15, 1987; Amdt. 36-16, 53 FR 47400, Nov. 22, 1988]

### **Appendix G to Part 36—Takeoff Noise Requirements for Propeller-Driven Small Airplane and Propeller-Driven, Commuter Category Airplane Certification Tests on or After December 22, 1988**

part a—general

Sec.

G36.1 *Scope.*

part b—noise measurement

G36.101 *General Test Conditions.*

G36.103 *Acoustical measurement system.*

G36.105 *Sensing, recording, and reproducing equipment.*

G36.107 *Noise measurement procedures.*

G36.109 *Data recording, reporting, and approval.*

G36.111 *Flight procedures.*

part c—data corrections

G36.201 *Corrections to Test Results.*

*G36.203 Validity of results.*

part d—noise limits

*G36.301 Aircraft Noise Limits.*

part a—general

*Section G36.1 Scope.* This appendix prescribes limiting noise levels and procedures for measuring noise and adjusting these data to standard conditions, for propeller driven small airplanes and propeller-driven, commuter category airplanes specified in §§36.1 and 36.501(c).

part b—noise measurement

*Sec. G36.101 General Test Conditions.*

- (a) The test area must be relatively flat terrain having no excessive sound absorption characteristics such as those caused by thick, matted, or tall grass, by shrubs, or by wooded areas. No obstructions which significantly influence the sound field from the airplane may exist within a conical space above the measurement position, the cone being defined by an axis normal to the ground and by a half-angle 75 degrees from the normal ground axis.
- (b) The tests must be carried out under the following conditions:
  - (1) No precipitation;
  - (2) Ambient air temperature between 36 and 95 degrees F (2.2 and 35 degrees C);
  - (3) Relative humidity between 20 percent and 95 percent, inclusively;
  - (4) Wind speed may not exceed 10 knots (19 km/h) and cross wind may not exceed 5 knots (9 km/h), using a 30-second average;
  - (5) No temperature inversion or anomalous wind condition that would significantly alter the noise level of the airplane when the noise is recorded at the required measuring point, and
  - (6) The meteorological measurements must be made between 4 ft. (1.2 m) and 33 ft. (10 m) above ground level. If the measurement site is within 1 n.m. of an airport meteorological station, measurements from that station may be used.
- (c) The flight test procedures, measuring equipment, and noise measurement procedures must be approved by the FAA.
- (d) Sound pressure level data for noise evaluation purposes must be obtained with acoustical equipment that complies with section G36.103 of this appendix.

*Sec. G36.103 Acoustical Measurement System.*

The acoustical measurement system must consist of approved equipment with the following

- characteristics: (a) A microphone system with frequency response compatible with measurement and analysis system accuracy as prescribed in section G36.105 of this appendix.
- (b) Tripods or similar microphone mountings that minimize interference with the sound being measured.
- (c) Recording and reproducing equipment characteristics, frequency response, and dynamic range compatible with the response and accuracy requirements of section G36.105 of this appendix.
- (d) Acoustic calibrators using sine wave or broadband noise of known sound pressure level. If broadband noise is used, the signal must be described in terms of its average and maximum root-mean-square (rms) value for non-overload signal level.

*Sec. G36.105 Sensing, Recording, and Reproducing Equipment.*

- (a) The noise produced by the airplane must be recorded. A magnetic tape recorder, graphic level recorder, or sound level meter is acceptable when approved by the regional certificating authority.
- (b) The characteristics of the complete system must comply with the requirements in International Electrotechnical Commission (IEC) Publications No. 651, entitled "Sound Level Meters" and No. 561, entitled "Electro-acoustical Measuring Equipment for Aircraft Noise Certification" as incorporated by reference under §36.6 of this part. Sound level meters must comply with the requirements for Type 1 sound level meters as specified in IEC Publication No. 651.
- (c) The response of the complete system to a sensibly plane progressive sinusoidal wave of constant amplitude must be within the tolerance limits specified in IEC Publication No. 651, over the frequency range 45 to 11,200 Hz.
- (d) If equipment dynamic range limitations make it necessary, high frequency pre-emphasis must be added to the recording channel with the converse de-emphasis on playback. The pre-emphasis must be applied such that the instantaneous recorded sound pressure level of the noise signal between 800 and 11,200 Hz does not vary more than 20 dB between the maximum and minimum one-third octave bands.
- (e) The output noise signal must be read through an "A" filter with dynamic characteristics designated "slow" as defined in IEC Publication No. 651. A graphic level recorder, sound level meter, or digital equivalent may be used.
- (f) The equipment must be acoustically calibrated using facilities for acoustic free-field calibration and if analysis of the tape recording is requested by the Administrator, the analysis equipment shall be electronically calibrated by a method approved by the FAA. Calibrations shall be performed, as appropriate, in accordance with paragraphs A36.3.8 and A36.3.9 of appendix A of this part.
- (g) A windscreen must be employed with the microphone during all measurements of aircraft noise

when the wind speed is in excess of 5 knots (9 km/hr).

*Sec. G36.107 Noise Measurement Procedures.*

- (a) The microphone must be a pressure type, 12.7 mm in diameter, with a protective grid, mounted in an inverted position such that the microphone diaphragm is 7 mm above and parallel to a white-painted metal circular plate. This white-painted metal plate shall be 40 cm in diameter and at least 2.5 mm thick. The plate shall be placed horizontally and flush with the surrounding ground surface with no cavities below the plate. The microphone must be located three-quarters of the distance from the center to the back edge of the plate along a radius normal to the line of flight of the test airplane.
- (b) Immediately prior to and after each test, a recorded acoustic calibration of the system must be made in the field with an acoustic calibrator for the purposes of checking system sensitivity and providing an acoustic reference level for the analysis of the sound level data. If a tape recorder or graphic level recorder is used, the frequency response of the electrical system must be determined at a level within 10 dB of the full-scale reading used during the test, utilizing pink or pseudorandom noise.
- (c) The ambient noise, including both acoustic background and electrical systems noise, must be recorded and determined in the test area with the system gain set at levels which will be used for aircraft noise measurements. If aircraft sound pressure levels do not exceed the background sound pressure levels by at least 10 dB(A), a takeoff measurement point nearer to the start of the takeoff roll must be used and the results must be adjusted to the reference measurement point by an approved method.

*Sec. G36.109 Data Recording, Reporting, and Approval.*

- (a) Data representing physical measurements and adjustments to measured data must be recorded in permanent form and appended to the record, except that corrections to measurements for normal equipment response deviations need not be reported. All other adjustments must be approved. Estimates must be made of the individual errors inherent in each of the operations employed in obtaining the final data.
- (b) Measured and corrected sound pressure levels obtained with equipment conforming to the specifications in section G36.105 of this appendix must be reported.
- (c) The type of equipment used for measurement and analysis of all acoustical, airplane performance, and meteorological data must be reported.
- (d) The following atmospheric data, measured immediately before, after, or during each test at the observation points prescribed in section G36.101 of this appendix must be reported:
  - (1) Ambient temperature and relative humidity.
  - (2) Maximum and average wind speeds and directions for each run.
- (e) Comments on local topography, ground cover, and events that might interfere with sound recordings must be reported.

- 
- (f) The aircraft position relative to the takeoff reference flight path must be determined by an approved method independent of normal flight instrumentation, such as radar tracking, theodolite triangulation, or photographic scaling techniques.
- (g) The following airplane information must be reported:
- (1) Type, model, and serial numbers (if any) of airplanes, engines, and propellers;
  - (2) Any modifications or nonstandard equipment likely to affect the noise characteristics of the airplane;
  - (3) Maximum certificated takeoff weight;
  - (4) For each test flight, airspeed and ambient temperature at the flyover altitude over the measuring site determined by properly calibrated instruments;
  - (5) For each test flight, engine performance parameters, such as manifold pressure or power, propeller speed (rpm) and other relevant parameters. Each parameter must be determined by properly calibrated instruments. For instance, propeller RPM must be validated by an independent device accurate to within  $\pm 1$  percent, when the airplane is equipped with a mechanical tachometer.
  - (6) Airspeed, position, and performance data necessary to make the corrections required in section G36.201 of this appendix must be recorded by an approved method when the airplane is directly over the measuring site.

*Sec. G36.111 Flight Procedures.*

- (a) The noise measurement point is on the extended centerline of the runway at a distance of 8200 ft (2500 m) from the start of takeoff roll. The aircraft must pass over the measurement point within  $\pm 10$  degrees from the vertical and within 20% of the reference altitude. The flight test program shall be initiated at the maximum approved takeoff weight and the weight shall be adjusted back to this maximum weight after each hour of flight time. Each flight test must be conducted at the speed for the best rate of climb ( $V_y$ )  $\pm 5$  knots ( $\pm 9$  km/hour) indicated airspeed. All test, measurement, and data correction procedures must be approved by the FAA.
- (b) The takeoff reference flight path must be calculated for the following atmospheric conditions:
  - (1) Sea level atmospheric pressure of 1013.25 mb (1013.25 hPa);
  - (2) Ambient air temperature of 59 °F (15 °C);
  - (3) Relative humidity of 70 percent; and
  - (4) Zero wind.
- (c) The takeoff reference flight path must be calculated assuming the following two segments:

(1) First segment.

- (i) Takeoff power must be used from the brake release point to the point at which the height of 50 ft (15m) above the runway is reached.
- (ii) A constant takeoff configuration selected by the applicant must be maintained through this segment.
- (iii) The maximum weight of the airplane at brake-release must be the maximum for which noise certification is requested.
- (iv) The length of this first segment must correspond to the airworthiness approved value for a takeoff on a level paved runway (or the corresponding value for seaplanes).

(2) Second segment.

- (i) The beginning of the second segment corresponds to the end of the first segment.
- (ii) The airplane must be in the climb configuration with landing gear up, if retractable, and flap setting corresponding to normal climb position throughout this second segment.
- (iii) The airplane speed must be the speed for the best rate of climb ( $V_y$ ).
- (iv) For airplanes equipped with fixed pitch propellers, takeoff power must be maintained throughout the second segment. For airplanes equipped with variable pitch or constant speed propellers, takeoff power and rpm must be maintained throughout the second segment. If airworthiness limitations do not allow the application of takeoff power and rpm up to the reference point, then takeoff power and rpm must be maintained for as long as is permitted by such limitations; thereafter, maximum continuous power and rpm must be maintained. Maximum time allowed at takeoff power under the airworthiness standards must be used in the second segment. The reference height must be calculated assuming climb gradients appropriate to each power setting used.

part c—data corrections

*Sec. G36.201 Corrections to Test Results.*

- (a) These corrections account for the effects of:
  - (1) Differences in atmospheric absorption of sound between meteorological test conditions and reference conditions.
  - (2) Differences in the noise path length between the actual airplane flight path and the reference flight path.
  - (3) The change in the helical tip Mach number between test and reference conditions.
  - (4) The change in the engine power between test and reference conditions.

- (b) Atmospheric absorption correction is required for noise data obtained when the test conditions are outside those specified in Figure G1. Noise data outside the applicable range must be corrected to 59 F and 70 percent relative humidity by an FAA approved method.

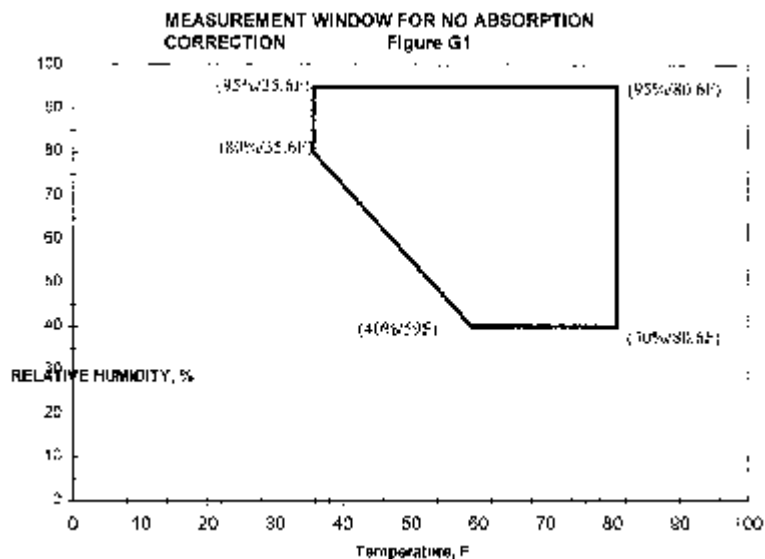

[View or download PDF](#)

- (c) No corrections for helical tip Mach number variation need to be made if the propeller helical tip Mach number is:
- (1) At or below 0.70 and the test helical tip Mach number is within 0.014 of the reference helical tip Mach number.
  - (2) Above 0.70 and at or below 0.80 and the test helical tip Mach number is within 0.007 of the reference helical tip Mach number.
  - (3) Above 0.80 and the test helical tip Mach number is within 0.005 of the reference helical tip Mach number. For mechanical tachometers, if the helical tip Mach number is above 0.8 and the test helical tip Mach number is within 0.008 of the reference helical tip Mach number.
- (d) When the test conditions are outside those specified, corrections must be applied by an approved procedure or by the following simplified procedure:
- (1) Measured sound levels must be corrected from test day meteorological conditions to reference conditions by adding an increment equal to

$$\Delta(M) = (H_T \alpha - 0.7 H_R) / 1000$$

where  $H_T$  is the height in feet under test conditions,  $H_R$  is the height in feet under reference conditions when the aircraft is directly over the noise measurement point and  $\alpha$  is the rate of absorption for the test day conditions at 500 Hz as specified in SAE ARP 866A, entitled "Standard Values of Atmospheric Absorption as a function of Temperature and Humidity for use in Evaluating Aircraft Flyover Noise" as incorporated by reference under §36.6.



- (2) Measured sound levels in decibels must be corrected for height by algebraically adding an increment equal to Delta (1). When test day conditions are within those specified in figure G1:

$$\Delta(1) = 22 \log(H_T/H_R)$$

where  $H_T$  is the height of the test aircraft when directly over the noise measurement point and  $H_R$  is the reference height.

When test day conditions are outside those specified in figure G1:

$$\Delta(1) = 20 \log(H_T/H_R)$$

- (3) Measured sound levels in decibels must be corrected for helical tip Mach number by algebraically adding an increment equal to:

$$\Delta(2) = k \log(M_R/M_T)$$

where  $M_T$  and  $M_R$  are the test and reference helical tip Mach numbers, respectively. The constant “k” is equal to the slope of the line obtained for measured values of the sound level in dB(A) versus helical tip Mach number. The value of k may be determined from approved data. A nominal value of k=150 may be used when  $M_T$  is smaller than  $M_R$ . No correction may be made using the nominal value of k when  $M_T$  is larger than  $M_R$ . The reference helical tip Mach number  $M_R$  is the Mach number corresponding to the reference conditions (RPM, airspeed, temperature) above the measurement point.

- (4) Measured sound levels in decibels must be corrected for engine power by algebraically adding an increment equal to

$$\Delta(3) = K_3 \log(P_R/P_T)$$

where  $P_R$  and  $P_T$  are the test and reference engine powers respectively obtained from the manifold pressure/torque gauges and engine rpm. The value of  $K_3$  shall be determined from approved data from the test airplane. In the absence of flight test data and at the discretion of the Administrator, a value of  $K_3=17$  may be used.

#### *Sec. G36.203 Validity of Results.*

- (a) The measuring point must be overflown at least six times. The test results must produce an average noise level ( $L_{Amax}$ ) value within a 90 percent confidence limit. The average noise level is the arithmetic average of the corrected acoustical measurements for all valid test runs over the measuring point.
- (b) The samples must be large enough to establish statistically a 90 percent confidence limit not exceeding  $\pm 1.5$  dB(A). No test results may be omitted from the averaging process unless omission is approved by the FAA.

part d—noise limits

*Sec. G36.301 Aircraft noise limits.*

- (a) Compliance with this section must be shown with noise data measured and corrected as prescribed in Parts B and C of this appendix.
- (b) For single-engine airplanes for which the original type certification application is received before February 3, 2006 and multi-engine airplanes, the noise level must not exceed 76 dB(A) up to and including aircraft weights of 1,320 pounds (600 kg). For aircraft weights greater than 1,320 pounds, the limit increases from that point with the logarithm of airplane weight at the rate of 9.83 dB (A) per doubling of weight, until the limit of 88 dB (A) is reached, after which the limit is constant up to and including 19,000 pounds (8,618 kg). Figure G2 shows noise level limits vs airplane weight.
- (c) For single-engine airplanes for which the original type certification application is received on or after February 3, 2006, the noise level must not exceed 70dB(A) for aircraft having a maximum certificated takeoff weight of 1,257 pounds (570 kg) or less. For aircraft weights greater than 1,257 pounds, the noise limit increases from that point with the logarithm of airplane weight at the rate of 10.75dB(A) per doubling of weight, until the limit of 85dB(A) is reached, after which the limit is constant up to and including 19,000 pounds (8,618 kg). Figure G2 depicts noise level limits for airplane weights for single-engine airplanes.

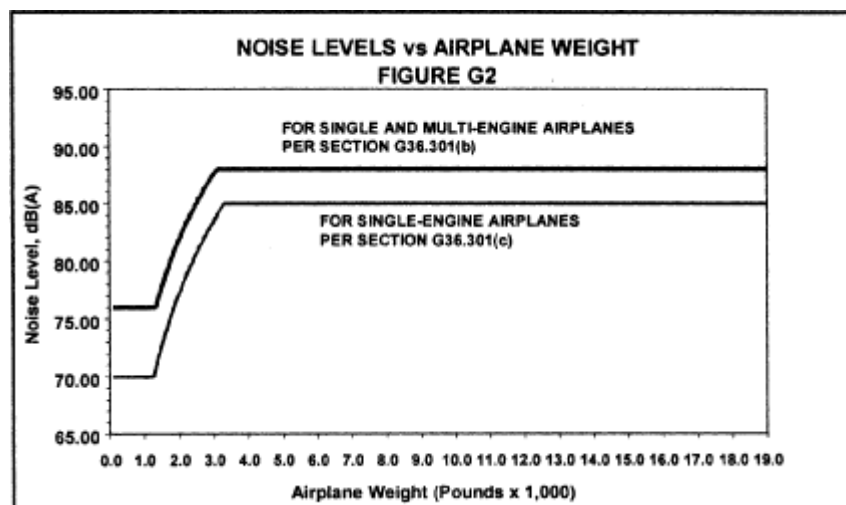

[View or download PDF](#)

(Secs. 313(a), 603, and 611(b), Federal Aviation Act of 1958 as amended (49 U.S.C. 1354(a), 1423, and 1431(b)); sec. 6(c), Department of Transportation Act (49 U.S.C. 1655 (c)); Title I, National Environmental Policy Act of 1969 (42 U.S.C. 4321 *et seq.*); E. O. 11514, March 5, 1970 and 14 CFR 11.45).

[Amdt. 36–16, 53 FR 47400, Nov. 22, 1988; 53 FR 50157, Dec. 13, 1988, as amended by Amdt. 36–22, 64 FR 55602, Oct. 13, 1999; Amdt. 36–54, 67 FR 45236, July 8, 2002; Amdt. 36–27, 70 FR 45504, Aug. 5, 2005; Amdt. 36–28, 71 FR 532, Jan. 4, 2006]

**Appendix H to Part 36—Noise Requirements For Helicopters Under Subpart H**

part a—reference conditions

Sec.

H36.1 *General.*

H36.3 *Reference Test Conditions.*

H36.5 *Symbols and Units.*

part b—noise measurement under §36.801

H36.101 *Noise certification test and measurement conditions.*

H36.103 *Takeoff test conditions.*

H36.105 *Flyover test conditions.*

H36.107 *Approach test conditions.*

H36.109 *Measurement of helicopter noise received on the ground.*

H36.111 *Reporting and correcting measured data.*

H36.113 *Atmospheric attenuation of sound.*

part c—noise evaluation and calculation under §36.803

H36.201 *Noise evaluation in EPNdB.*

H36.203 *Calculation of noise levels.*

H36.205 *Detailed data correction procedures.*

part d—noise limits under §36.805

H36.301 *Noise measurement, evaluation, and calculation.*

H36.303 [Reserved]

H36.305 *Noise levels.*

part a—reference conditions

*Section H36.1 General.* This appendix prescribes noise requirements for helicopters specified under §36.1, including:

(a) The conditions under which helicopter noise certification tests under Part H must be conducted and the measurement procedures that must be used under §36.801 to measure helicopter

noise during each test;

- (b) The procedures which must be used under §36.803 to correct the measured data to the reference conditions and to calculate the noise evaluation quantity designated as Effective Perceived Noise Level (EPNL); and
- (c) The noise limits for which compliance must be shown under §36.805.

*Section H36.3 Reference Test Conditions.*

(a) *Meteorological conditions.* Aircraft position, performance data and noise measurements must be corrected to the following noise certification reference atmospheric conditions which shall be assumed to exist from the surface to the aircraft altitude:

(1) Sea level pressure of 2,116 psf (1,013.25 hPa).

(2) Ambient temperature of 77 degrees F (25 degrees C).

(3) Relative humidity of 70 percent.

(4) Zero wind.

(b) *Reference test site.* The reference test site is flat and without line-of-sight obstructions across the flight path that encompasses the 10 dB down points.

(c) *Takeoff reference profile.* (1) Figure H1 illustrates a typical takeoff profile, including reference conditions.

(2) The reference flight path is defined as a straight line segment inclined from the starting point (1,640 feet (500 meters) from the center microphone location and 65 feet (20 meters) above ground level) at a constant climb angle  $\beta$  defined by the certificated best rate of climb and  $V_y$  for minimum engine performance. The constant climb angle  $\beta$  is derived from the manufacturer's data (approved by the FAA) to define the flight profile for the reference conditions. The constant climb angle  $\beta$  is drawn through  $C_r$  and continues, crossing over station A, to the position corresponding to the end of the type certification takeoff path represented by position  $I_r$ .

(d) *Level flyover reference profile.* The beginning of the level flyover reference profile is represented by helicopter position  $D_r$  (Figure H2). The helicopter approaches position  $D_r$  in level flight 492 feet above ground level as measured at Station A. Reference airspeed must be either  $0.9V_H$ ;  $0.9V_{NE}$ ;  $0.45V_H + 65$  kts ( $0.45V_H + 120$  km/h); or  $0.45V_{NE} + 65$  kts ( $0.45V_{NE} + 120$  km/h), whichever of the four speeds is least. The helicopter crosses directly overhead station A in level flight and proceeds to position  $J_r$ .

(e) For noise certification purposes,  $V_H$  is defined as the airspeed in level flight obtained using the minimum specified engine torque corresponding to maximum continuous power available for sea level pressure of 2,116 psf (1,013.25 hPa) at 77 °F (25 °C) ambient conditions at the relevant maximum certificated weight. The value of  $V_{NE}$  is the never-exceed airspeed. The values of  $V_H$  and  $V_{NE}$  that are used for noise certification must be listed in the approved

## Rotorcraft Flight Manual.

- (f) *Approach reference profile.* (1) Figure H3 illustrates approach profile, including reference conditions.
- (i) The beginning of the approach profile is represented by helicopter position E. The position of the helicopter is recorded for a sufficient distance (EK) to ensure recording of the entire interval during which the measured helicopter noise level is within 10 dB of Maximum Tone Corrected Perceived Noise Level (PNLTM). The reference flight path,  $E_rK_r$ , represents a stable flight condition in terms of torque, rpm, indicated airspeed, and rate of descent resulting in a  $6^\circ$  approach angle.
- (ii) The test approach profile is defined by the approach angle  $\eta$  passing directly over the station A at a height of AH, to position K, which terminates the approach noise certification profile. The test approach angle  $\eta$  must be between  $5.5^\circ$  and  $6.5^\circ$ .
- (2) The helicopter approaches position H along a constant  $6^\circ$  approach slope throughout the 10 dB down time period. The helicopter crosses position E and proceeds along the approach slope crossing over station A until it reaches position K.

*Section H36.5 Symbols and units.* The following symbols and units as used in this appendix for helicopter noise certification have the following meanings.

### Flight Profile Identification—Positions

Position	Description
A	Location of the noise measuring point at the flight-track noise measuring station vertically below the reference (takeoff, flyover, or approach) flight path.
C	Start of noise certification takeoff flight path.
$C_r$	Start of noise certification reference takeoff flight path.
D	Start of noise certification flyover flight path.
$D_r$	Start of noise certification reference flyover path.
E	Start of noise certification approach flight path.
$E_r$	Start of noise certification reference approach flight path.
F	Position on takeoff flight path directly above noise measuring station A.
$F_r$	Position on reference takeoff path directly above noise measuring Station A.
G	Position on flyover flight path directly above noise measuring station A.
$G_r$	Position on reference flyover path directly above noise measuring Station A.
H	Position on approach flight path directly above noise measuring station A.
$H_r$	Position on reference path directly above noise measuring Station A.

I	End of noise type certification takeoff flight path.
I <sub>r</sub>	End of noise type certification reference takeoff flight path.
J	End of noise type certification flyover flight path.
J <sub>r</sub>	End of noise type certification reference flyover flight path.
K	End of noise certification approach type flight path.
K <sub>r</sub>	End of noise type certification reference approach flight path.
L	Position on measured takeoff flight path corresponding to PNLTM at station A.
L <sub>r</sub>	Position on reference takeoff flight path corresponding to PNLTM of station A.
M	Position on measured flyover flight path corresponding to PNLTM of station A.
M <sub>r</sub>	Position on reference flyover flight path corresponding to PNLTM of station A.
N	Position on measured approach flight path corresponding to PNLTM at station A.
N <sub>r</sub>	Position on reference approach flight path corresponding to PNLTM at station A.
S	Sideline noise measuring station (note: a subscript denotes the aircraft orientation relative to the direction of flight).

### Flight Profile Distances

Distance	Unit	Meaning
AF	Feet	<i>Takeoff Height.</i> The vertical distance between helicopter and station A.
AG	Feet	<i>Flyover Height.</i> The vertical distance between the helicopter and station A.
AH	Feet	<i>Approach Height.</i> The vertical distance between the helicopter and station A.
AL	Feet	<i>Measured Takeoff Noise Path.</i> The distance from station A to the measured helicopter position L.
AL <sub>r</sub>	Feet	<i>Reference Takeoff Noise Path.</i> The distance from station A to the reference helicopter position L <sub>r</sub> .
AM	Feet	<i>Measured Flyover Noise Path.</i> The distance from station A to the measured helicopter position M.
AM <sub>r</sub>	Feet	<i>Reference Flyover Noise Path.</i> The distance from station A to helicopter position M <sub>r</sub> on the reference flyover flight path.
AN	Feet	<i>Measured Approach Noise Path.</i> The distance from station A to the measured helicopter noise position N.
AN <sub>r</sub>	Feet	<i>Reference Approach Noise Path.</i> The distance from station A to the reference helicopter position N <sub>r</sub> .
CI	Feet	<i>Takeoff Flight Path Distance.</i> The distance from position C at which the helicopter establishes a constant climb angle on the takeoff flight path passing over

		station A and continuing to position I at which the position of the helicopter need no longer be recorded.
DJ	Feet	<i>Flyover Flight Path Distance.</i> The distance from position D at which the helicopter is established on the flyover flight path passing over station A and continuing to position J at which the position of the helicopter need no longer be recorded.
EK	Feet	<i>Approach Flight Path Distance.</i> The distance from position E at which the helicopter establishes a constant angle on the approach flight path passing over station A and continuing to position K at which the position of the helicopter need no longer be recorded.

part b—noise measurement under §36.801

*Section H36.101 Noise certification test and measurement conditions.*

- (a) *General.* This section prescribes the conditions under which aircraft noise certification tests must be conducted and the measurement procedures that must be used to measure helicopter noise during each test.
- (b) *Test site requirements.* (1) Tests to show compliance with established helicopter noise certification levels must consist of a series of takeoffs, level flyovers, and approaches during which measurement must be taken at noise measuring stations located at the measuring points prescribed in this section.
- (2) Each takeoff test, flyover test, and approach test includes simultaneous measurements at the flight-track noise measuring station vertically below the reference flight path and at two sideline noise measuring stations, one on each side of the reference flight track 492 feet (150m) from, and on a line perpendicular to, the flight track of the noise measuring station.
- (3) The difference between the elevation of either sideline noise measuring station may not differ from the flight-track noise measuring station by more than 20 feet.
- (4) Each noise measuring station must be surrounded by terrain having no excessive sound absorption characteristics, such as might be caused by thick, matted, or tall grass, shrubs, or wooded areas.
- (5) During the period when the takeoff, flyover, or approach noise/time record indicates the noise measurement is within 10 dB of PNLTM, no obstruction that significantly influences the sound field from the aircraft may exist—
- (i) For any flight-track or sideline noise measuring station, within a conical space above the measuring position (the point on the ground vertically below the microphone), the cone being defined by an axis normal to the ground and by half-angle 80° from this axis; and
- (ii) For any sideline noise measuring station, above the line of sight between the microphone and the helicopter.
- (6) If a takeoff or flyover test series is conducted at weights other than the maximum takeoff weight

for which noise certification is requested, the following additional requirements apply:

- (i) At least one takeoff test and one flyover test must be conducted at, or above, the maximum certification weight.
  - (ii) Each test weight must be within +5 percent or –10 percent of the maximum certification weight.
- (7) Each approach test must be conducted with the aircraft stabilized and following a 6.0 degree  $\pm 0.5$  degree approach angle and must meet the requirements of section H36.107 of this part.
- (8) If an approach test series is conducted at weights other than the maximum landing weight for which certification is requested, the following additional requirements apply:
- (i) At least one approach test must be conducted at a weight at, or above, the maximum landing weight.
  - (ii) Each test weight must be between +5 percent and –10 percent of the maximum certification weight.
- (c) *Weather restrictions.* The tests must be conducted under the following atmospheric conditions:
- (1) No rain or other precipitation.
  - (2) Ambient air temperature between 14 °F and 95 °F (–10 °C and 35 °C), inclusively, at a point 33 feet (10 meters) above the ground at the noise measuring station and at the aircraft. The temperature and relative humidity measured at a point 33 feet (10 meters) above the ground at the noise measuring station must be used to adjust for propagation path absorption.
  - (3) Relative humidity and ambient temperature at a point 33 feet (10 meters) above the ground at the noise measuring station and at the aircraft, is such that the sound attenuation in the one-third octave band centered at 8 kHz is not greater than 12 dB/100 meters and the relative humidity is between 20 percent and 95 percent, inclusively.
  - (4) Wind velocity as measured at 10 meters above ground does not exceed 10 knots (19 km/h) and the crosswind component does not exceed 5 knots (9 km/h). The wind shall be determined using a continuous thirty-second averaging period spanning the 10dB down time interval.
  - (5) No anomalous meteorological conditions (including turbulence) that will significantly affect the noise level of the aircraft when the noise is recorded at each noise measuring station.
  - (6) The wind velocity, temperature, and relative humidity measurements required under the appendix must be measured in the vicinity of noise measuring stations 10 meters above the ground. The location of the meteorological measurements must be approved by the FAA as representative of those atmospheric conditions existing near the surface over the geographical area which aircraft noise measurements are made. In some cases, a fixed meteorological station (such as those found at airports or other facilities) may meet this requirement.



- (7) Temperature and relative humidity measurements must be obtained within 30 minutes of each noise test.
- (d) *Aircraft testing procedures.* (1) The aircraft testing procedures and noise measurements must be conducted and processed in a manner that yields the noise evaluation measure designated as Effective Perceived Noise Level (EPNL) in units of EPNdB, as prescribed in Appendix A of this part.
- (2) The helicopter height and lateral position relative to the reference flight track (which passes through the flight track noise measuring station) must be determined using an FAA-approved method. The equipment used to make the determination must be independent of normal flight instrumentation. Applicable independent systems are radar tracking, theodolite triangulation, laser trajectography, photo scaling, or differential global positioning system.
- (3) The helicopter position along the flight path must be related to the noise recorded at the noise measuring stations by means of synchronized signals recorded at an approved sampling rate. The helicopter position must be recorded relative to the reference flight track during the entire time interval in which the recorded signal is within 10 dB of PNLTM. Measuring and sampling equipment must be approved by the FAA before testing.
- (4) Aircraft performance data sufficient to make the corrections required under section H36.205 of this appendix must be recorded at an FAA-approved sampling rate using FAA-approved equipment.

*Section H36.103 Takeoff test conditions.*

- (a) This section, in addition to the applicable requirements of sections H36.101 and H36.205(b) of this appendix, applies to all takeoff noise tests conducted under this appendix to show compliance with Part 36.
- (b) A test series must consist of at least six flights over the flight-track noise measuring station (with simultaneous measurements at all three noise measuring stations) as follows:
- (1) An airspeed of either  $V_y \pm 5$  knots or the lowest approved speed  $\pm 5$  knots for the climb after takeoff, whichever speed is greater, must be established and maintained throughout the 10 dB-down time interval.
- (2) The horizontal portion of each test flight must be conducted at an altitude of 65 feet (20 meters) above the ground level at the flight-track noise measuring station.
- (3) Upon reaching a point 1,640 feet (500 meters) from the noise measuring station, the helicopter must be stabilized at the maximum takeoff power that corresponds to minimum installed engine(s) specification power available for the reference ambient conditions or gearbox torque limit, whichever is lower.
- (4) The helicopter must be maintained throughout the 10 dB-down time interval at the best rate of climb speed  $V_y \pm 5$  knots, or the lowest approved speed for climb after takeoff, whichever is greater, for an ambient temperature of 25 °C at sea level.

- (5) The average rotor speed must not vary from the maximum normal operating rotor RPM by more than  $\pm 1.0$  percent during the 10 dB-down time interval.
- (6) The helicopter must stay within  $\pm 10^\circ$  or  $\pm 65$  feet ( $\pm 20$  meters), whichever is greater, from the vertical above the reference track throughout the 10dB-down time interval.
- (7) A constant takeoff configuration selected by the applicant must be maintained throughout the takeoff reference procedure with the landing gear position consistent with the airworthiness certification tests for establishing best rate-of-climb speed,  $V_y$ .

*Section H36.105 Flyover test conditions.*

- (a) This section, in addition to the applicable requirements of sections H36.101 and H36.205(c) of this appendix, applies to all flyover noise tests conducted under this appendix to show compliance with Part 36.
  - (b) A test series consists of at least six flights. The number of level flights made with a headwind component must be equal to the number of level flights made with a tailwind component with simultaneous measurements at all three noise measuring stations—
    - (1) In level flight cruise configuration;
    - (2) At a height of 492 feet  $\pm 30$  feet (150  $\pm 9$  meters) above the ground level at the flight-track noise measuring station; and
    - (3) The helicopter must fly within  $\pm 10^\circ$  or  $\pm 65$  feet ( $\pm 20$  meters), whichever is greater, from the vertical above the reference track throughout the 10 dB-down time interval.
  - (c) Each flyover noise test must be conducted—
    - (1) At a speed of  $0.9V_H$ ;  $0.9V_{NE}$ ;  $0.45V_H + 65$  kts ( $0.45V_H + 120$  km/h); or  $0.45V_{NE} + 65$  kts ( $0.45V_{NE} + 120$  km/h), whichever speed is least, to be maintained throughout the measured portion of the flyover;
    - (2) At average rotor speed, which must not vary from the maximum normal operating rotor RPM by more than  $\pm 1.0$  percent during the 10 dB-down time interval.
    - (3) With the power stabilized during the period when the measured helicopter noise level is within 10 dB of PNLTM.
  - (d) The airspeed shall not vary from the reference airspeed by more than  $\pm 5$  knots (9 km/hr).

*Section H36.107 Approach test conditions.*

- (a) This section, in addition to the requirements of sections H36.101 and H36.205(d) of this appendix, applies to all approach tests conducted under this appendix to show compliance with Part 36.
- (b) A test series must consist of at least six flights over the flight-track noise measuring station

(with simultaneous measurements at the three noise measuring stations)—

- (1) On an approach slope of  $6^\circ \pm 0.5^\circ$ ;
  - (2) At a height of  $394 \pm 33$  feet ( $120 \pm 10$  meters)
  - (3) The helicopter must fly within  $\pm 10^\circ$  or  $\pm 65$  feet ( $\pm 20$  meters) lateral deviation tolerance, whichever is greater, from the vertical above the reference track throughout the 10 dB-down time interval;
  - (4) At stabilized airspeed equal to the certificated best rate of climb  $V_y$ , or the lowest approved speed for approach, whichever is greater, with power stabilized during the approach and over the flight path reference point, and continued to a normal touchdown; and
  - (5) At average rotor speed, which may not vary from the maximum normal operating rotor RPM by more than  $\pm 1.0$  percent during the 10 dB-down time interval; and
  - (6) The constant approach configuration used in airworthiness certification tests, with the landing gear extended, must be maintained throughout the approach reference procedure.
- (c) The airspeed shall not vary from the reference airspeed by more than  $\pm 5$  knots ( $\pm 9$  km/hr).

*Section H36.109 Measurement of Helicopter Noise Received on the Ground.*

The measurement system and the measurement, calibration and general analysis procedures to be used are provided in Appendix A, section A36.3 of this part.

*Section H36.111 Reporting and correcting measured data.*

- (a) *General.* Data representing physical measurements, and corrections to measured data, including corrections to measurements for equipment response deviations, must be recorded in permanent form and appended to the record. Each correction must be reported and is subject to FAA approval. An estimate must be made of each individual error inherent in each of the operations employed in obtaining the final data.
- (b) *Data reporting.* (1) Measured and corrected sound pressure levels must be presented in one-third octave band levels obtained with equipment conforming to the standards prescribed in section H36.109 of this appendix.
- (2) The type of equipment used for measurement and analysis of all acoustic, aircraft performance, and meteorological data must be reported.
- (3) The atmospheric environmental data required to demonstrate compliance with this appendix, measured throughout the test period, must be reported.
- (4) Conditions of local topography, ground cover, or events which may interfere with sound recording must be reported.
- (5) The following aircraft information must be reported:

- (i) Type, model, and serial numbers, if any, of aircraft engines and rotors.
  - (ii) Gross dimensions of aircraft and location of engines.
  - (iii) Aircraft gross weight for each test run.
  - (iv) Aircraft configuration, including landing gear positions.
  - (v) Airspeed in knots.
  - (vi) Helicopter engine performance as determined from aircraft instruments and manufacturer's data.
  - (vii) Aircraft flight path, above ground level in feet, determined by an FAA approved method which is independent of normal flight instrumentation, such as radar tracking, theodolite triangulation, laser trajectography, or photographic scaling techniques.
- (6) Aircraft speed, and position, and engine performance parameters must be recorded at an approved sampling rate sufficient to correct to the noise certification reference test conditions prescribed in section H36.3 of this appendix. Lateral position relative to the reference flight-track must be reported.
- (c) *Data corrections.* (1) Aircraft position, performance data and noise measurement must be corrected to the noise certification reference conditions as prescribed in sections H36.3 and H36.205 of this appendix.
- (2) The measured flight path must be corrected by an amount equal to the difference between the applicant's predicted flight path for the certification reference conditions and the measured flight path at the test conditions. Necessary corrections relating to helicopter flight path or performance may be derived from FAA-approved data for the difference between measured and reference conditions, together with appropriate allowances for sound attenuation with distance. The Effective Perceived Noise Level (EPNL) correction may not exceed 2.0 EPNdB except for takeoff flight condition, where the correction may not exceed 4.0 EPNdB, of which the arithmetic sum of  $\Delta_1$  (described in section H36.205(f)(1)) and the term  $-7.5 \log (AL/AL_r)$  from  $\Delta_2$  term (described in section H36.205(g)(1)(i)) may not exceed 2.0 EPNdB, for any combination of the following:
- (i) The helicopter not passing vertically above the measuring station.
  - (ii) Any difference between the reference flight track and the actual test flight track; and
  - (iii) Detailed correction requirements prescribed in section H36.205 of this appendix.
- (3) Helicopter sound pressure levels within the 10 dB-down time interval must exceed the mean background sound pressure levels determined under section B36.3.9.11 by at least 3 dB in each one-third octave band, or must be corrected under an FAA-approved method.
- (d) *Validity of results.* (1) The test results must produce three average EPNL values within the 90 percent confidence limits, each value consisting of the arithmetic average of the corrected

noise measurements for all valid test runs at the takeoff, level flyovers, and approach conditions. The 90 percent confidence limit applies separately to takeoff, flyover, and approach.

- (2) The minimum sample size acceptable for each takeoff, approach, and flyover certification measurements is six. The number of samples must be large enough to establish statistically for each of the three average noise certification levels a 90 percent confidence limit which does not exceed  $\pm 1.5$  EPNdB. No test result may be omitted from the averaging process, unless otherwise specified by the FAA.
- (3) To comply with this appendix, a minimum of six takeoffs, six approaches, and six level flyovers is required. To be counted toward this requirement, each flight event must be validly recorded at all three noise measuring stations.
- (4) The approved values of  $V_H$  and  $V_y$  used in calculating test and reference conditions and flight profiles must be reported along with measured and corrected sound pressure levels.

*Section H36.113 Atmospheric attenuation of sound.*

- (a) The values of the one-third octave band spectra measured during helicopter noise certification tests under this appendix must conform, or be corrected, to the reference conditions prescribed in section H36.3(a). Each correction must account for any differences in the atmospheric attenuation of sound between the test-day conditions and the reference-day conditions along the sound propagation path between the aircraft and the microphone. Unless the meteorological conditions are within the test window prescribed in this appendix, the test data are not acceptable.
- (b) *Attenuation rates.* The procedure for determining the atmospheric attenuation rates of sound with distance for each one-third octave bands must be determined in accordance with Society of Automotive Engineering (SAE) ARP 866A. The atmospheric attenuation equations are provided in both the International and English system of units in section A36.7 of this part.
- (c) *Correction for atmospheric attenuation.* (1) EPNL values calculated for measured data must be corrected whenever—
  - (i) The ambient atmospheric conditions of temperature and relative humidity do not conform to the reference conditions, 77 °F and 70%, respectively, or
  - (ii) The measured flight paths do not conform to the reference flight paths.
  - (iii) The temperature and relative humidity measured at 33 feet (10 meters) above the ground must be used to adjust for propagation path absorption.
- (2) The mean attenuation rate over the complete sound propagation path from the aircraft to the microphone must be computed for each one-third octave band from 50 Hz to 10,000 Hz. These rates must be used in computing the corrections required in section H36.111(d) of this appendix.

part c—noise evaluation and calculation under §36.803

*Section H36.201 Noise Evaluation in EPNdB.*

(a) Effective Perceived Noise Level (EPNL), in units of effective perceived noise decibels (EPNdB), shall be used for evaluating noise level values under §36.803 of this part. Except as provided in paragraph (b) of this section, the procedures in appendix A of Part 36 must be used for computing EPNL. appendix A includes requirements governing determination of noise values, including calculations of:

- (1) Perceived noise levels;
- (2) Corrections for spectral irregularities;
- (3) Tone corrections;
- (4) Duration corrections;
- (5) Effective perceived noise levels; and
- (6) Mathematical formulation of noise tables.

(b) Notwithstanding the provisions of section A36.4.3.1(a), for helicopter noise certification, corrections for spectral irregularities shall start with the corrected sound pressure level in the 50 Hz one-third octave band.

*Section H36.203 Calculation of noise levels.*

- (a) To demonstrate compliance with the noise level limits of section H36.305, the noise values measured simultaneously at the three noise measuring points must be arithmetically averaged to obtain a single EPNdB value for each flight.
- (b) The calculated noise level for each noise test series, i.e., takeoff, flyover, or approach must be the numerical average of at least six separate flight EPNdB values. The 90 percent confidence limit for all valid test runs under section H36.111(d) of this appendix applies separately to the EPNdB values for each noise test series.

*Section H36.205 Detailed data correction procedures.*

(a) *General.* If the test conditions do not conform to those prescribed as noise certification reference conditions under section H36.305 of this appendix, the following correction procedure shall apply:

(1) If there is any difference between measured test and reference conditions, an appropriate correction must be made to the EPNL calculated from the measured noise data. Conditions that can result in a different value include:

(i) Atmospheric absorption of sound under measured test conditions that are different from the reference test conditions; or

- (ii) Measured flight path that is different from the reference flight path.
- (2) The following correction procedures may produce one or more possible correction values which must be added algebraically to the calculated EPNL to bring it to reference conditions:
- (i) The flight profiles must be determined for both reference and test conditions. The procedures require noise and flight path recording with a synchronized time signal from which the test profile can be delineated, including the aircraft position for which PNLTM is observed at the noise measuring station. For takeoff, the flight profile corrected to reference conditions may be derived from FAA approved manufacturer's data.
- (ii) The sound propagation paths to the microphone from the aircraft position corresponding to PNLTM must be determined for both the test and reference profiles. The SPL values in the spectrum of PNLTM must then be corrected for the effects of—
- (A) Change in atmospheric sound absorption;
- (B) Atmospheric sound absorption on the linear difference between the two sound path lengths; and
- (C) Inverse square law on the difference in sound propagation path length. The corrected values of SPL must then be converted to a reference condition PNLTM value from which PNLTM must be subtracted. The resulting difference represents the correction which must be added algebraically to the EPNL calculated from the measured data.
- (iii) As observed at the noise measuring station, the measured PNLTM distance is different from the reference PNLTM distance and therefore the ratio must be calculated and used to determine a noise duration correction factor. Effective perceived noise level, EPNL, is determined by the algebraic sum of the maximum tone corrected perceived noise level (PNLTM) and the duration correction factor.
- (iv) For aircraft flyover, alternative source noise corrections require FAA approval and must be determined and adjusted to account for noise level changes caused by the differences between measured test conditions and reference conditions.
- (b) *Takeoff profiles.* (1) Figure H1 illustrates a typical takeoff profile, including reference conditions.
- (i) The reference takeoff flight path is described in section H36.3(c).
- (ii) The test parameters are functions of the helicopter's performance and weight and the atmospheric conditions of temperature, pressure, wind velocity and direction.
- (2) For the actual takeoff, the helicopter approaches position C in level flight at 65 feet (20 meters) above ground level at the flight track noise measuring station and at either  $V_y \pm 5$  knots or the lowest approved speed for the climb after takeoff, whichever speed is greater.

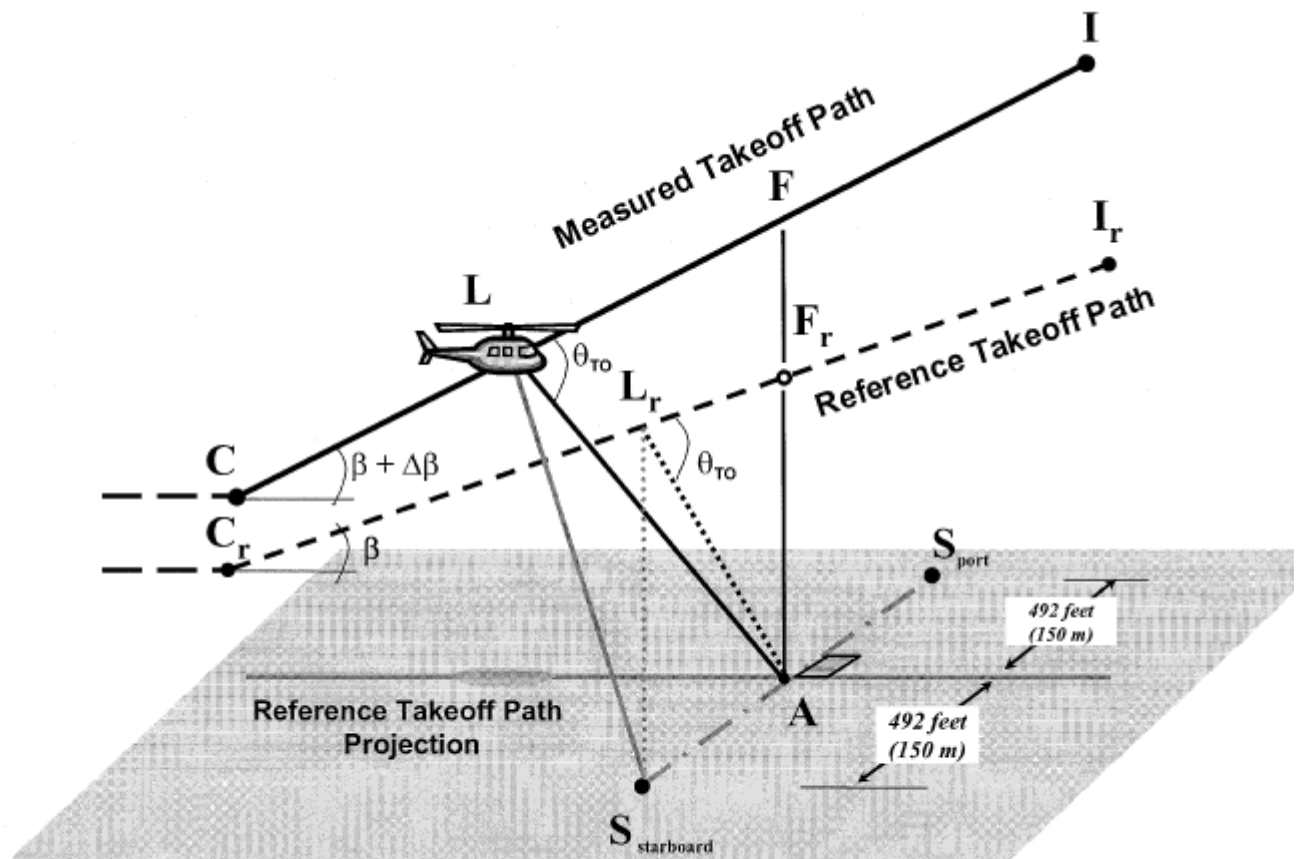
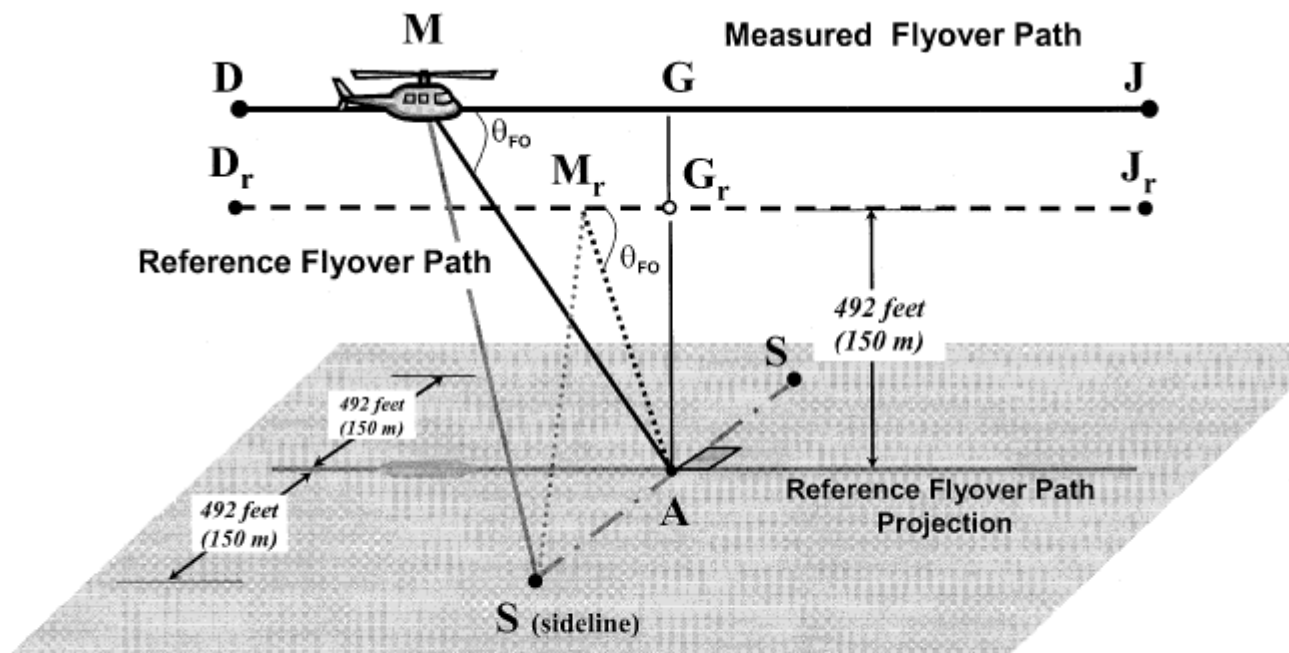

**Figure H1.**  
**Comparison of Measured and Reference Takeoff Profiles**

[View or download PDF](#)

- (3) Figure H1 illustrates the significant geometrical relationships influencing sound propagation. Position L represents the helicopter location on the measured takeoff path from which PNLTM is observed at station A, and  $L_r$  is the corresponding position on the reference sound propagation path. Propagation paths AL and  $AL_r$  both form the same angle  $\Theta$  (theta) relative to their respective flight paths.
- (c) *Level flyover profiles.* (1) The noise type certification level flyover profile is shown in Figure H2. Airspeed must be stabilized within  $\pm 5$  knots of the reference airspeed determined using the procedures in section H36.3(d). The number of level flights made with a headwind component must be equal to the number of level flights made with a tailwind component.

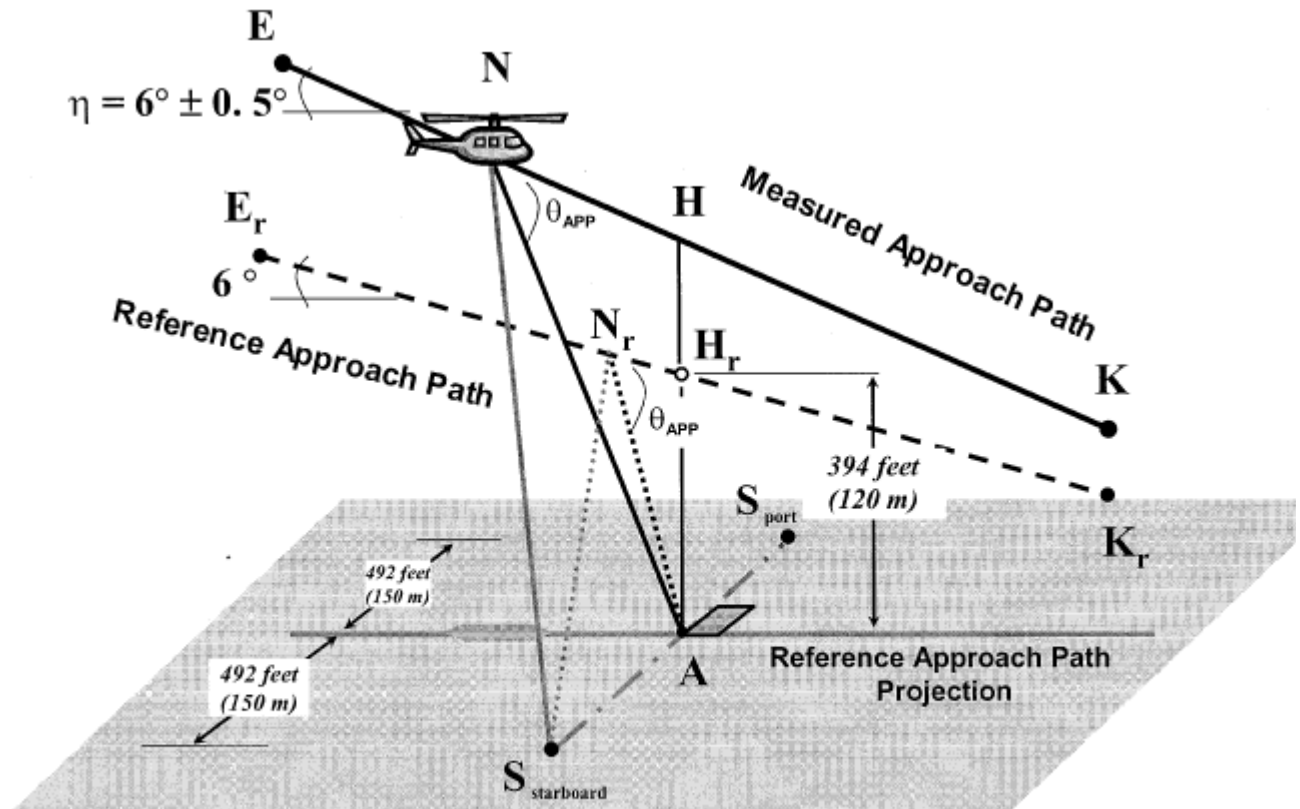



**Figure H2.**  
**Comparison of Measured and Reference Flyover Profiles**

[View or download PDF](#)

- (2) Figure H2 illustrates comparative flyover profiles when test conditions do not conform to prescribed reference conditions. The position of the helicopter shall be recorded for a distance (DJ) sufficient to ensure recording of the entire interval during which the measured helicopter noise level is within 10 dB of PNLTM, as required. The flyover profile is defined by the height AG which is a function of the operating conditions controlled by the pilot. Position M represents the helicopter location on the measured flyover flight path for which PNLTM is observed at station A, and M<sub>r</sub> is the corresponding position on the reference flight path.
- (d) *Approach profiles.* (1) Figure H3 illustrates a typical approach profile, including reference conditions.
- (2) The helicopter approaches position H along a 6° (±0.5°) average approach slope throughout the 10dB-down time interval. Deviation from the 6° average approach slope must be approved by the FAA before testing.



**Figure H3.**  
**Comparison of Measured and Reference Approach Profiles**

[View or download PDF](#)

- (3) Figure H3 illustrates portions of the measured and reference approach flight paths including the significant geometrical relationships influencing sound propagation. The measured approach path is represented by segment EK with an approach allowable angle  $\Theta$ . Reference positions,  $E_r$  and  $K_r$ , define an idealized reference approach angle of  $6^\circ$ . Position N represents the helicopter location on the measured approach flight path for which PNLTM is observed at measuring station A, and  $N_r$  is the corresponding position on the reference approach flight path. The measured and reference noise propagation paths are AN and  $AN_r$ , respectively, both of which form the same angle,  $\Theta_{APP}$ , corresponding to PNLTM relative to their approach flight paths.
- (e) *Correction of noise at source during level flyover.* (1) For level overflight, if any combination of the following three factors, airspeed deviations from reference, rotor speed deviations from reference, and temperature deviations from reference, results in a noise correlating parameter whose value deviates from the reference value of this parameter, then source noise adjustments must be determined from the manufacturer's data that is approved by the FAA.
- (2) Off-reference tip Mach number adjustments must be based upon a sensitivity curve of PNLTM versus advancing blade tip Mach number, deduced from overflights performed at different airspeeds surrounding the reference airspeed. If the test aircraft is unable to attain the reference value, then an extrapolation of the sensitivity curve is permitted if data cover at least a range of 0.03 Mach units. The advancing blade tip Mach number must be computed

using true airspeed, onboard outside air temperature, and rotor speed. A separate PNLTM versus advancing blade tip Mach number function must be derived for each of the three certification microphone locations, *i.e.*, centerline, sideline left, and sideline right. Sideline left and right are defined relative to the direction of flight for each run. PNLTM adjustments are to be applied to each microphone datum using the appropriate PNLTM function.

(f) *PNLT corrections.* If the measured ambient atmospheric conditions of temperature and relative humidity differ from those prescribed as reference conditions under this appendix (77 degrees F and 70 percent, respectively), corrections to the EPNL values must be calculated from the measured data under paragraph (a) of this section as follows:

(1) *Takeoff flight path.* For the takeoff flight path shown in Figure H1, the spectrum of PNLTM observed at station A for the aircraft at position L is decomposed into its individual  $SPL(i)$  values.

(i) Step 1. A set of corrected values are then computed as follows:

$$SPL(i)_r = SPL(i) + C [\alpha(i) - \alpha(i)_o]AL + C_{\alpha(i)_o}(AL - AL_r) + 20 \log (AL/AL_r)$$

where  $SPL(i)$  and  $SPL(i)_r$  are the measured and corrected sound pressure levels, respectively, in the  $i$ -th one-third octave band. The first correction term adjusts for the effect of change in atmospheric sound absorption where  $\alpha(i)$  and  $\alpha(i)_o$  are the sound attenuation coefficients for the test and reference atmospheric conditions, respectively, for the  $i$ -th one-third octave band, and  $AL$  is the measured takeoff sound propagation path. The conversion factor constant,  $C$ , is 0.001 for English System of Units and is 0.01 for International System of Units. The second correction term adjusts for the effects of atmospheric attenuation due to the difference in the sound propagation path length where  $AL_r$  is the Reference takeoff sound propagation path. The third correction term, known as the "inverse square" law, adjusts for the effect of the difference in the sound propagation path lengths.

(ii) Step 2. The corrected values of the  $SPL(i)_r$  are then converted to reference condition PNLT and a correction term calculated as follows:

$$\Delta_1 = PNLT - PNLTM$$

which represents the correction to be added algebraically to the EPNL calculated from the measured data.

(2) *Level flyover flight path.* (i) The procedure described in paragraph (f)(1) of this section for takeoff paths is also used for the level flyover paths, with the values of  $SPL(i)_r$  relating to the flyover sound propagation paths shown in Figure H2 as follows:

$$SPL(i)_r = SPL(i) + C [\alpha(i) - \alpha(i)_o]AM + C_{\alpha(i)_o}(AM - AM_r) + 20 \log (AM/AM_r)$$

where the lines  $AM$  and  $AM_r$  are the measured and reference level flyover sound propagation paths, respectively.

(ii) The remainder of the procedure is the same for the flyover condition as that prescribed in the paragraph (f)(1)(ii) of this section regarding takeoff flight path.

(3) *Approach flight path.* (i) The procedure described in paragraph (f)(1) of this section for takeoff paths is also used for the approach paths, with the values of  $SPL(i)_r$  relating to the approach sound propagation paths shown in Figure H3 as follows:

$$SPL(i)_r = SPL(i) + C_{[\alpha(i) - \alpha(i)_o]} AN + C_{\alpha(i)_o} (AN - AN_r) + 20 \log (AN/AN_r)$$

where the lines AN and AN<sub>r</sub> are the measured and reference approach sound propagation paths, respectively.

(ii) The remainder of the procedure is the same for the approach condition as that prescribed in the paragraph (f)(1)(ii) of this section regarding takeoff flight path.

(4) *Sideline microphones.* (i) The procedure prescribed in paragraph (f)(1) of this section for takeoff paths is also used for the propagation to the sideline locations, with the values of  $SPL(i)_r$  relating as follows to the measured sideline sound propagation path shown in Figure H3 as follows:

$$SPL(i)_r = SPL(i) + C_{[\alpha(i) - \alpha(i)_o]} SX + C_{\alpha(i)_o} (SX - SX_r) + 20 \log (SX/SX_r)$$

where S is the sideline measuring station and, based upon the flight condition, the helicopter positions, X and X<sub>r</sub>, correspond to:

X = L, and X<sub>r</sub> = L<sub>r</sub> for takeoff

X = M, and X<sub>r</sub> = M<sub>r</sub> for flyover

X = N, and X<sub>r</sub> = N<sub>r</sub> for approach

(ii) The remainder of the procedure is the same for the sideline paths as that prescribed in the paragraph (f)(1)(ii) of this section regarding takeoff flight paths.

(g) *Duration corrections.* (1) If the measured takeoff and approach flight paths do not conform to those prescribed as the corrected and reference flight paths, respectively, under section A36.5(d)(2) it will be necessary to apply duration corrections to the EPNL values calculated from the measured data. Such corrections must be calculated as follows:

(i) *Takeoff flight path.* For the takeoff path shown in Figure H1, the correction term is calculated using the formula—

$$\Delta_2 = -7.5 \log (AL/AL_r) + 10 \log (V/V_r)$$

which represents the correction that must be added algebraically to the EPNL calculated from the measured data. The lengths AL and AL<sub>r</sub> are the measured and reference takeoff distances from the noise measuring station A to the measured and the reference takeoff paths, respectively. A negative sign indicates that, for the particular case of a duration correction, the EPNL calculated from the measured data must be reduced if the measured takeoff path

is at greater altitude than the reference takeoff path.

(ii) *Level flyover flight paths.* For the level flyover flight path, the correction term is calculated using the formula—

$$\Delta_2 = -7.5 \log (AM/AM_r) + 10 \log (V/V_r)$$

where AM is the measured flyover distance from the noise measuring station A to the measured flyover path, and AM<sub>r</sub> is the reference distance from station A to the reference flyover path.

(iii) *Approach flight path.* For the approach path shown in Figure H3, the correction term is calculated using the formula—

$$\Delta_2 = -7.5 \log (AN/AN_r) + 10 \log (V/V_r)$$

where AN is the measured approach distance from the noise measuring station A to the measured approach path, and AN<sub>r</sub> is the reference distance from station A to the reference approach path.

(iv) *Sideline microphones.* For the sideline flight path, the correction term is calculated using the formula—

$$\Delta_2 = -7.5 \log (SX/SX_r) + 10 \log (V/V_r)$$

where S is the sideline measuring station and based upon the flight condition, the helicopter positions, X and X<sub>r</sub>, correspond to:

X = L, and X<sub>r</sub> = L<sub>r</sub> for takeoff

X = M, and X<sub>r</sub> = M<sub>r</sub> for flyover

X = N, and X<sub>r</sub> = N<sub>r</sub> for approach

(2) The adjustment procedure described in this section shall apply to the sideline microphones in the take-off, overflight, and approach cases. Although the noise emission is strongly dependent on the directivity pattern, variable from one helicopter type to another, the propagation angle  $\Theta$  shall be the same for test and reference flight paths. The elevation angle  $\psi$  shall not be constrained but must be determined and reported. The certification authority shall specify the acceptable limitations on  $\psi$ . Corrections to data obtained when these limits are exceeded shall be applied using FAA approved procedures.

part d—noise limits under §36.805

*Section H36.301 Noise measurement, evaluation, and calculation.*

Compliance with this part of this appendix must be shown with noise levels measured, evaluated, and calculated as prescribed under Parts B and C of this appendix.

*Section H36.303 [Reserved]*

*Section H36.305 Noise levels.*

(a) *Limits.* For compliance with this appendix, it must be shown by flight test that the calculated noise levels of the helicopter, at the measuring points described in section H36.305(a) of this appendix, do not exceed the following, with appropriate interpolation between weights:

(1) *Stage 1* noise limits for acoustical changes for helicopters are as follows:

(i) For takeoff, flyover, and approach calculated noise levels, the noise levels of each Stage 1 helicopter that exceed the Stage 2 noise limits plus 2 EPNdB may not, after a change in type design, exceed the noise levels created prior to the change in type design.

(ii) For takeoff, flyover, and approach calculated noise levels, the noise levels of each Stage 1 helicopter that do not exceed the Stage 2 noise limits plus 2 EPNdB may not, after the change in type design, exceed the Stage 2 noise limits plus 2 EPNdB.

(2) *Stage 2* noise limits are as follows:

(i) *For takeoff calculated noise levels* —109 EPNdB for maximum takeoff weights of 176,370 pounds (80,000 kg) or more, reduced by 3.01 EPNdB per halving of the weight down to 89 EPNdB, after which the limit is constant.

(ii) *For flyover calculated noise levels* —108 EPNdB for maximum weights of 176,370 pounds (80,000 kg) or more, reduced by 3.01 EPNdB per halving of the weight down to 88 EPNdB, after which the limit is constant.

(iii) *For approach calculated noise levels* —110 EPNdB for maximum weights of 176,370 pounds (80,000 kg) or more, reduced by 3.01 EPNdB per halving of the weight down to 90 EPNdB, after which the limit is constant.

(b) *Tradeoffs.* Except to the extent limited under §36.11(b) of this part, the noise limits prescribed in paragraph (a) of this section may be exceeded by one or two of the takeoff, flyover, or approach calculated noise levels determined under section H36.203 of this appendix if

(1) The sum of the exceedances is not greater than 4 EPNdB;

(2) No exceedance is greater than 3 EPNdB; and

(3) The exceedances are completely offset by reduction in the other required calculated noise levels.

[Amdt. 36–14, 53 FR 3541, Feb. 5, 1988; 53 FR 4099, Feb. 11, 1988; 53 FR 7728, Mar. 10, 1988, as amended by Amdt. 36–54, 67 FR 45237, July 8, 2002; Amdt. 36–25, 69 FR 31234, June 2, 2004; Amdt. 36–25, 69 FR 41573, July 9, 2004]

**Appendix I to Part 36 [Reserved]****Appendix J to Part 36—Alternative Noise Certification Procedure for Helicopters Under Subpart H Having a Maximum Certificated Takeoff Weight of Not More Than 7,000**

## **Pounds**

part a—reference conditions

Sec.

J36.1 *General.*

J36.3 *Reference Test Conditions.*

J36.5 [Reserved]

part b—noise measurement procedure under §36.801

J36.101 *Noise certification test and measurement conditions.*

J36.103 [Reserved]

J36.105 *Flyover test conditions.*

J36.107 [Reserved]

J36.109 *Measurement of helicopter noise received on the ground.*

J36.111 *Reporting requirements.*

J36.113 [Reserved]

part c—noise evaluation and calculation under §36.803

J36.201 *Noise evaluation in SEL.*

J36.203 *Calculation of noise levels.*

J36.205 *Detailed data correction procedures.*

part d—noise limits procedure under §36.805

J36.301 *Noise measurement, evaluation, and calculation.*

J36.303 [Reserved]

J36.305 *Noise limits.*

part a—reference conditions

*Section J36.1 General.*

This appendix prescribes the alternative noise certification requirements identified under §36.1 of

this part and subpart H of this part for helicopters in the primary, normal, transport, and restricted categories having maximum certificated takeoff weight of not more than 7,000 pounds including:

- (a) The conditions under which an alternative noise certification test under subpart H of this part must be conducted and the alternative measurement procedure that must be used under §36.801 of this part to measure the helicopter noise during the test;
- (b) The alternative procedures which must be used under §36.803 of this part to correct the measured data to the reference conditions and to calculate the noise evaluation quantity designated as Sound Exposure Level (SEL); and
- (c) The noise limits for which compliance must be shown under §36.805 of this part.

*Section J36.3 Reference Test Conditions.*

- (a) *Meteorological conditions.* The following are the noise certification reference atmospheric conditions which shall be assumed to exist from the surface to the helicopter altitude:
  - (1) Sea level pressure of 2116 pounds per square foot (76 centimeters mercury);
  - (2) Ambient temperature of 77 degrees Fahrenheit (25 degrees Celsius);
  - (3) Relative humidity of 70 percent; and
  - (4) Zero wind.
- (b) *Reference test site.* The reference test site is flat and without line-of-sight obstructions across the flight path that encompasses the 10 dB down points of the A-weighted time history.
- (c) *Level flyover reference profile.* The reference flyover profile is a level flight, 492 feet (150 meters) above ground level as measured at the noise measuring station. The reference flyover profile has a linear flight track and passes directly over the noise monitoring station. Airspeed is stabilized at  $0.9V_H$ ;  $0.9V_{NE}$ ;  $0.45V_H + 65$  kts (120 km/h); or  $0.45V_{NE} + 65$  kts (120 km/h), whichever of the four airspeeds is least, and maintained throughout the measured portion of the flyover. Rotor speed is stabilized at the maximum normal operating RPM throughout the 10 dB-down time interval.
  - (1) For noise certification purposes,  $V_H$  is defined as the airspeed in level flight obtained using the minimum specification engine power corresponding to maximum continuous power available for sea level pressure of 2,116 psf (1,013.25 hPa) at 77 °F (25 °C) ambient conditions at the relevant maximum certificated weight. The value of  $V_H$  and  $V_{NE}$  used for noise certification must be included in the Flight Manual.
  - (2)  $V_{NE}$  is the never-exceed airspeed.
- (d) The weight of the helicopter shall be the maximum takeoff weight at which noise certification is requested.



*Section J36.5 [Reserved]*

## Part B—Noise Measurement Procedure Under §36.801

*Section J36.101 Noise certification test and measurement conditions.*

- (a) *General.* This section prescribes the conditions under which helicopter noise certification tests must be conducted and the measurement procedures that must be used to measure helicopter noise during each test.
- (b) *Test site requirements.* (1) The noise measuring station must be surrounded by terrain having no excessive sound absorption characteristics, such as might be caused by thick, matted, or tall grass, shrubs, or wooded areas.
- (2) During the period when the flyover noise measurement is within 10 dB of the maximum A-weighted sound level, no obstruction that significantly influences the sound field from the helicopter may exist within a conical space above the noise measuring position (the point on the ground vertically below the microphone), the cone is defined by an axis normal to the ground and by half-angle 80 degrees from this axis.
- (c) *Weather restrictions.* The test must be conducted under the following atmospheric conditions:
- (1) No rain or other precipitation;
- (2) Ambient air temperature between 36 degrees and 95 degrees Fahrenheit (2 degrees and 35 degrees Celsius), inclusively, and relative humidity between 20 percent and 95 percent inclusively, except that testing may not take place where combinations of temperature and relative humidity result in a rate of atmospheric attenuation greater than 10 dB per 100 meters (30.5 dB per 1000 ft) in the one-third octave band centered at 8 kiloHertz.
- (3) Wind velocity that does not exceed 10 knots (19 km/h) and a crosswind component that does not exceed 5 knots (9 km/h). The wind shall be determined using a continuous averaging process of no greater than 30 seconds;
- (4) Measurements of ambient temperature, relative humidity, wind speed, and wind direction must be made between 4 feet (1.2 meters) and 33 feet (10 meters) above the ground. Unless otherwise approved by the FAA, ambient temperature and relative humidity must be measured at the same height above the ground.
- (5) No anomalous wind conditions (including turbulence) or other anomalous meteorological conditions that will significantly affect the noise level of the helicopter when the noise is recorded at the noise measuring station; and
- (6) If the measurement site is within 6560 feet (2,000 meters) of a fixed meteorological station (such as those found at airports or other facilities) the weather measurements reported for temperature, relative humidity and wind velocity may be used, if approved by the FAA.
- (d) *Helicopter testing procedures.* (1) The helicopter testing procedures and noise measurements must be conducted and processed in a manner which yields the noise evaluation measure

designated Sound Exposure Level (SEL) as defined in section J36.109(b) of this appendix.

- (2) The helicopter height relative to the noise measurement point sufficient to make corrections required under section J36.205 of this appendix must be determined by an FAA-approved method that is independent of normal flight instrumentation, such as radar tracking, theodolite triangulation, laser trajectography, or photographic scaling techniques.
- (3) If an applicant demonstrates that the design characteristics of the helicopter would prevent flight from being conducted in accordance with the reference test conditions prescribed under section J36.3 of this appendix, then with FAA approval, the reference test conditions used under this appendix may vary from the standard reference test conditions, but only to the extent demanded by those design characteristics which make compliance with the reference test conditions impossible.

*Section J36.103 [Reserved]*

*Section J36.105 Flyover test conditions.*

- (a) This section prescribes the flight test conditions and allowable random deviations for flyover noise tests conducted under this appendix.
- (b) A test series must consist of at least six flights. The number of level flights made with a headwind component must be equal to the number of level flights made with a tailwind component over the noise measurement station:
  - (1) In level flight and in cruise configuration;
  - (2) At a height of 492 feet  $\pm$ 50 feet (150  $\pm$ 15 meters) above the ground level at the noise measuring station; and
  - (3) Within  $\pm$ 10 degrees from the zenith.
- (c) Each flyover noise test must be conducted:
  - (1) At the reference airspeed specified in section J36.3(c) of this appendix, with such airspeed adjusted as necessary to produce the same advancing blade tip Mach number as associated with the reference conditions;
    - (i) Advancing blade tip Mach number ( $M_{AT}$ ) is defined as the ratio of the arithmetic sum of blade tip rotational speed ( $V_R$ ) and the helicopter true air speed ( $V_T$ ) over the speed of sound ( $c$ ) at 77 degrees Fahrenheit (1135.6 ft/sec or 346.13 m/sec) such that  $M_{AT}=(V_R+V_T)/c$ ; and
    - (ii) The airspeed shall not vary from the adjusted reference airspeed by more than  $\pm$ 3 knots ( $\pm$ 5 km/hr) or an equivalent FAA-approved variation from the reference advancing blade tip Mach number. The adjusted reference airspeed shall be maintained throughout the measured portion of the flyover.
  - (2) At rotor speed stabilized at the power on maximum normal operating rotor RPM ( $\pm$ 1 percent); and

- (3) With the power stabilized during the period when the measured helicopter noise level is within 10 dB of the maximum A-weighted sound level ( $L_{AMAX}$ ).
- (d) The helicopter test weight for each flyover test must be within plus 5 percent or minus 10 percent of the maximum takeoff weight for which certification under this part is requested.
- (e) The requirements of paragraph (b)(2) of this section notwithstanding, flyovers at an FAA-approved lower height may be used and the results adjusted to the reference measurement point by an FAA-approved method if the ambient noise in the test area, measured in accordance with the requirements prescribed in section J36.109 of this appendix, is found to be within 15 dB(A) of the maximum A-weighted helicopter noise level ( $L_{AMAX}$ ) measured at the noise measurement station in accordance with section J36.109 of this appendix.

*Section J36.107 [Reserved]*

*Section J36.109 Measurement of helicopter noise received on the ground.*

- (a) *General.* (1) The helicopter noise measured under this appendix for noise certification purposes must be obtained with FAA-approved acoustical equipment and measurement practices.
- (2) Paragraph (b) of this section identifies and prescribes the specifications for the noise evaluation measurements required under this appendix. Paragraphs (c) and (d) of this section prescribe the required acoustical equipment specifications. Paragraphs (e) and (f) of this section prescribe the calibration and measurement procedures required under this appendix.
- (b) *Noise unit definition.* (1) The value of sound exposure level (SEL, or as denoted by symbol,  $L_{AE}$ ), is defined as the level, in decibels, of the time integral of squared 'A'-weighted sound pressure ( $P_A$ ) over a given time period or event, with reference to the square of the standard reference sound pressure ( $P_0$ ) of 20 micropascals and a reference duration of one second.

- (2) This unit is defined by the expression:

$$L_{AE} = 10 \text{ Log}_{10} \frac{1}{T_0} \int_{t_1}^{t_2} \left( \frac{P_A(t)}{P_0} \right)^2 dt \text{ dB}$$

Where  $T_0$  is the reference integration time of one second and  $(t_2-t_1)$  is the integration time interval.

- (3) The integral equation of paragraph (b)(2) of this section can also be expressed as:

$$L_{AE} = 10 \text{ Log}_{10} \frac{1}{T_0} \int_{t_1}^{t_2} 10^{0.1L_A(t)} dt \text{ dB}$$

Where  $L_A(t)$  is the time varying A-weighted sound level.

- (4) The integration time  $(t_2-t_1)$  in practice shall not be less than the time interval during which  $L_A(t)$

first rises to within 10 dB(A) of its maximum value ( $L_{AMAX}$ ) and last falls below 10 dB(A) of its maximum value.

(5) The SEL may be approximated by the following expression:

$$L_{AE} = L_{AMAX} + \langle \text{delta} \rangle A$$

where  $\langle \text{delta} \rangle A$  is the duration allowance given by:

$$\langle \text{delta} \rangle A = 10 \log_{10}(T)$$

where  $T = (t_2 - t_1)/2$  and  $L_{AMAX}$  is defined as the maximum level, in decibels, of the A-weighted sound pressure (slow response) with reference to the square of the standard reference sound pressure ( $P_0$ ).

(c) *Measurement system.* The acoustical measurement system must consist of FAA-approved equipment equivalent to the following:

- (1) A microphone system with frequency response that is compatible with the measurement and analysis system accuracy prescribed in paragraph (d) of this section;
- (2) Tripods or similar microphone mountings that minimize interference with the sound energy being measured;
- (3) Recording and reproducing equipment with characteristics, frequency response, and dynamic range that are compatible with the response and accuracy requirements of paragraph (d) of this section; and
- (4) The calibration and checking of measurement systems must use the procedures described in Section A36.3.9.

(d) *Sensing, recording, and reproducing equipment.* (1) The noise levels measured from helicopter flyovers under this appendix may be determined directly by an integrating sound level meter, or the A-weighted sound level time history may be written onto a graphic level recorder set at “slow” response from which the SEL value may be determined. With the approval of the FAA, the noise signal may be tape recorded for subsequent analysis.

(i) The SEL values from each flyover test may be directly determined from an integrating sound level meter complying with the Standards of the International Electrotechnical Commission (IEC) Publication No. 804, “Integrating-averaging Sound Level Meters,” as incorporated by reference under §36.6 of this part, for a Type 1 instrument set at “slow” response.

(ii) The acoustic signal from the helicopter, along with the calibration signals specified under paragraph (e) of this section and the background noise signal required under paragraph (f) of this section may be recorded on a magnetic tape recorder for subsequent analysis by an integrating sound level meter identified in paragraph (d)(1)(i) of this section. The record/playback system (including the audio tape) of the tape recorder must conform to the requirements prescribed in section A36.3.6 of appendix A of this part. The tape recorder

shall comply with specifications of IEC Publication No. 561, "Electro-acoustical Measuring Equipment for Aircraft Noise Certification," as incorporated by reference under §36.6 of this part.

- (iii) The characteristics of the complete system shall comply with the recommendations given in IEC Publication No. 651, "Sound Level Meters," as incorporated by reference under §36.6 of this part, with regard to the specifications concerning microphone, amplifier, and indicating instrument characteristics.
  - (iv) The response of the complete system to a sensibly plane progressive wave of constant amplitude shall lie within the tolerance limits specified in Table IV and Table V for Type 1 instruments in IEC Publication No. 651, "Sound Level Meters," as incorporated by reference under §36.6 of this part, for weighting curve "A" over the frequency range of 45 Hz to 11500 Hz.
  - (v) A windscreen must be used with the microphone during each measurement of the helicopter flyover noise. Correction for any insertion loss produced by the windscreen, as a function of the frequency of the acoustic calibration required under paragraph (e) of this section, must be applied to the measured data and any correction applied must be reported.
- (e) *Calibrations.* (1) If the helicopter acoustic signal is tape recorded for subsequent analysis, the measuring system and components of the recording system must be calibrated as prescribed under section A36.3.6 of appendix A of this part.
- (2) If the helicopter acoustic signal is directly measured by an integrating sound level meter:
- (i) The overall sensitivity of the measuring system shall be checked before and after the series of flyover tests and at intervals (not exceeding one-hour duration) during the flyover tests using an acoustic calibrator using sine wave noise generating a known sound pressure level at a known frequency.
  - (ii) The performance of equipment in the system will be considered satisfactory if, during each day's testing, the variation in the calibration value does not exceed 0.5 dB. The SEL data collected during the flyover tests shall be adjusted to account for any variation in the calibration value.
  - (iii) A performance calibration analysis of each piece of calibration equipment, including acoustic calibrators, reference microphones, and voltage insertion devices, must have been made during the six calendar months proceeding the beginning of the helicopter flyover series. Each calibration shall be traceable to the National Institute of Standards and Technology.
- (f) *Noise measurement procedures.* (1) The microphone shall be of the pressure-sensitive capacitive type designed for nearly uniform grazing incidence response. The microphone shall be mounted with the center of the sensing element 4 feet (1.2 meters) above the local ground surface and shall be oriented for grazing incidence such that the sensing element, the diaphragm, is substantially in the plane defined by the nominal flight path of the helicopter and the noise measurement station.
- (2) If a tape recorder is used, the frequency response of the electrical system must be determined at

a level within 10 dB of the full-scale reading used during the test, utilizing pink or pseudorandom noise.

- (3) The ambient noise, including both acoustical background and electrical noise of the measurement systems shall be determined in the test area and the system gain set at levels which will be used for helicopter noise measurements. If helicopter sound levels do not exceed the background sound levels by at least 15 dB(A), flyovers at an FAA-approved lower height may be used and the results adjusted to the reference measurement point by an FAA-approved method.
- (4) If an integrating sound level meter is used to measure the helicopter noise, the instrument operator shall monitor the continuous A-weighted (slow response) noise levels throughout each flyover to ensure that the SEL integration process includes, at minimum, all of the noise signal between the maximum A-weighted sound level ( $L_{AMAX}$ ) and the 10 dB down points in the flyover time history. The instrument operator shall note the actual db(A) levels at the start and stop of the SEL integration interval and document these levels along with the value of  $L_{AMAX}$  and the integration interval (in seconds) for inclusion in the noise data submitted as part of the reporting requirements under section J36.111(b) of this appendix.

#### *Section J36.111 Reporting Requirements.*

- (a) *General.* Data representing physical measurements, and corrections to measured data, including corrections to measurements for equipment response deviations, must be recorded in permanent form and appended to the record. Each correction is subject to FAA approval.
- (b) *Data reporting.* After the completion of the test the following data must be included in the test report furnished to the FAA:
  - (1) Measured and corrected sound levels obtained with equipment conforming to the standards prescribed in section J36.109 of this appendix;
  - (2) The type of equipment used for measurement and analysis of all acoustic, aircraft performance and flight path, and meteorological data;
  - (3) The atmospheric environmental data required to demonstrate compliance with this appendix, measured throughout the test period;
  - (4) Conditions of local topography, ground cover, or events which may interfere with the sound recording;
  - (5) The following helicopter information:
    - (i) Type, model, and serial numbers, if any, of helicopter, engine(s) and rotor(s);
    - (ii) Gross dimensions of helicopter, location of engines, rotors, type of antitorque system, number of blades for each rotor, and reference operating conditions for each engine and rotor;
    - (iii) Any modifications of non-standard equipment likely to affect the noise characteristics of the

helicopter;

- (iv) Maximum takeoff weight for which certification under this appendix is requested;
  - (v) Aircraft configuration, including landing gear positions;
  - (vi)  $V_{HOR}$  or  $V_{NE}$  (whichever is less) and the adjusted reference airspeed;
  - (vii) Aircraft gross weight for each test run;
  - (viii) Indicated and true airspeed for each test run;
  - (ix) Ground speed, if measured, for each run;
  - (x) Helicopter engine performance as determined from aircraft instruments and manufacturer's data; and
  - (xi) Aircraft flight path above ground level, referenced to the elevation of the noise measurement station, in feet, determined by an FAA-approved method which is independent of normal flight instrumentation, such as radar tracking, theodolite triangulation, laser trajectography, or photostaging techniques; and
- (6) Helicopter position and performance data required to make the adjustments prescribed under section J36.205 of this appendix and to demonstrate compliance with the performance and position restrictions prescribed under section J36.105 of this appendix must be recorded at an FAA-approved sampling rate.

*Section J36.113 [Reserved]*

Part C—Noise Evaluation and Calculations Under §36.803

*Section J36.201 Noise Evaluation in SEL.*

The noise evaluation measure shall be the sound exposure level (SEL) in units of dB(A) as prescribed under section J36.109(b) of this appendix. The SEL value for each flyover may be directly determined by use of an integrating sound level meter. Specifications for the integrating sound level meter and requirements governing the use of such instrumentation are prescribed under section J36.109 of this appendix.

*Section J36.203 Calculation of Noise Levels.*

(a) To demonstrate compliance with the noise level limits specified under section J36.305 of this appendix, the SEL noise levels from each valid flyover, corrected as necessary to reference conditions under section J36.205 of this appendix, must be arithmetically averaged to obtain a single SEL dB(A) mean value for the flyover series. No individual flyover run may be omitted from the averaging process, unless otherwise specified or approved by the FAA.

(b) The minimum sample size acceptable for the helicopter flyover certification measurements is

six. The number of samples must be large enough to establish statistically a 90 percent confidence limit that does not exceed  $\pm 1.5$  dB(A).

- (c) All data used and calculations performed under this section, including the calculated 90 percent confidence limits, must be documented and provided under the reporting requirements of section J36.111 of this appendix.

*Section J36.205 Detailed Data Correction Procedures.*

- (a) When certification test conditions measured under part B of this appendix differ from the reference test conditions prescribed under section J36.3 of this appendix, appropriate adjustments shall be made to the measured noise data in accordance with the methods set out in paragraphs (b) and (c) of this section. At minimum, appropriate adjustments shall be made for off-reference altitude and for the difference between reference airspeed and adjusted reference airspeed.

- (b) The adjustment for off-reference altitude may be approximated from:

$$\langle \Delta \rangle_{J_1} = 12.5 \log_{10}(H_T/492) \text{ dB};$$

where  $\langle \Delta \rangle_{J_1}$  is the quantity in decibels that must be algebraically added to the measured SEL noise level to correct for an off-reference flight path,  $H_T$  is the height, in feet, of the test helicopter when directly over the noise measurement point, and the constant (12.5) accounts for the effects on spherical spreading and duration from the off-reference altitude.

- (c) The adjustment for the difference between reference airspeed and adjusted reference airspeed is calculated from:

$$\langle \Delta \rangle_{J_3} = 10 \log_{10}(V_{RA}/V_R) \text{ dB};$$

Where  $\langle \Delta \rangle_{J_3}$  is the quantity in decibels that must be algebraically added to the measured SEL noise level to correct for the influence of the adjustment of the reference airspeed on the duration of the measured flyover event as perceived at the noise measurement station,  $V_R$  is the reference airspeed as prescribed under section J36.3.(c) of this appendix, and  $V_{RA}$  is the adjusted reference airspeed as prescribed under section J36.105(c) of this appendix.

- (d) No correction for source noise during the flyover other than the variation of source noise accounted for by the adjustment of the reference airspeed prescribed for under section J36.105(c) of this appendix need be applied.

- (e) No correction for the difference between the reference ground speed and the actual ground speed need be applied.

- (f) No correction for off-reference atmospheric attenuation need be applied.

- (g) The SEL adjustments must be less than 2.0 dB(A) for differences between test and reference flight procedures prescribed under section J36.105 of this appendix unless a larger adjustment value is approved by the FAA.



(h) All data used and calculations performed under this section must be documented and provided under the reporting requirements specified under section J36.111 of this appendix.

#### Part D—Noise Limits Procedure Under §36.805

##### *Section J36.301 Noise Measurement, Evaluation, and Calculation.*

Compliance with this part of this appendix must be shown with noise levels measured, evaluated, and calculated as prescribed under parts B and C of this appendix.

##### *Section J36.303 [Reserved]*

##### *Section J36.305 Noise Limits.*

For compliance with this appendix, the calculated noise levels of the helicopter, at the measuring point described in section J36.101 of this appendix, must be shown to not exceed the following (with appropriate interpolation between weights):

- (a) For primary, normal, transport, and restricted category helicopters having a maximum certificated takeoff weight of not more than 7,000 pounds that are noise tested under this appendix, the Stage 2 noise limit is 82 decibels SEL for helicopters up to 1,737 pounds maximum certificated takeoff weight at which the noise certification is requested, and increasing at a rate of 3.0 decibels per doubling of weight thereafter. The limit may be calculated by the equation:  $L_{AE}(\text{limit}) = 82 + 3.0 [\log_{10}(\text{MTOW}/1737)/\log_{10}(2)]$  dB, where MTOW is the maximum takeoff weight, in pounds, for which certification under this appendix is requested.
- (b) The procedures required in this amendment shall be done in accordance with the International Electrotechnical Commission IEC Publication No. 804, entitled “Integrating-averaging Sound Level Meters,” First Edition, dated 1985. This incorporation by reference was approved by the Director of the Federal Register in accordance with 5 U.S.C. 552(a) and 1 CFR part 51. Copies may be obtained from the Bureau Central de la Commission Electrotechnique Internationale, 1, rue de Varembe, Geneva, Switzerland or the American National Standard Institute, 1430 Broadway, New York City, New York 10018, or at the National Archives and Records Administration (NARA). For information on the availability of this material at NARA, call 202-741-6030, or go to: [http://www.archives.gov/federal\\_register/code\\_of\\_federal\\_regulations/ibr\\_locations.html](http://www.archives.gov/federal_register/code_of_federal_regulations/ibr_locations.html).

[Doc. No. 26910, 57 FR 42855, Sept. 16, 1992, as amended by Amdt. 36-20, 57 FR 46243, Oct. 7, 1992; 69 FR 18803, Apr. 9, 2004; Amdt. 36-25, 69 FR 31234, June 2, 2004]